

STANDARD PLANS



ORANGE COUNTY

**RESOURCES & DEVELOPMENT
MANAGEMENT DEPARTMENT**

2006 EDITION

BRYAN G. SPEEGLE, DIRECTOR

ADOPTED BY RESOLUTION OF BOARD OF SUPERVISORS
RESOLUTION NO. 06-010

STANDARD PLAN REFERENCE

STANDARD PLANS 100 THROUGH 636

STANDARD PLANS FOR PUBLIC WORKS CONSTRUCTION (1997 EDITION)

AMERICAN PUBLIC WORKS ASSOCIATION
SOUTHERN CALIFORNIA CHAPTER

ASSOCIATED GENERAL CONTRACTORS OF CALIFORNIA
SOUTHERN CALIFORNIA DISTRICTS

JOINT COOPERATIVE COMMITTEE

COPIES OF STANDARD PLANS FOR PUBLIC WORKS CONSTRUCTION,
1997 EDITION, ARE PUBLISHED AND DISTRIBUTED ON BEHALF OF
THE JOINT COOPERATIVE COMMITTEE BY:

BNI BOOKS, DIVISION OF BUILDING NEWS, INC
1612 S. Clementine St.
ANAHEIM, CA 92802. (888) 264-2665, FAX : (714) 533-1467

STANDARD PLANS 1100 THROUGH 1809

STANDARD PLANS FOR ORANGE COUNTY RESOURCES & DEVELOPMENT MANAGEMENT DEPARTMENT

COPIES OF STANDARD PLANS FOR ORANGE COUNTY
RESOURCES & DEVELOPMENT MANAGEMENT DEPARTMENT
ARE AVAILABLE AT:

RESOURCES & DEVELOPMENT MANAGEMENT DEPARTMENT
POST OFFICE BOX 4048 (MAILING ADDRESS)
300 N. FLOWER STREET (STREET ADDRESS)
SANTA ANA, CALIFORNIA 92702-4048 (714) 834-4585

PREFACE

The Standard Plans for Public Works Construction of the American Public Works Association (Southern California Chapter) and Associated General Contractors of California (Southern California District) are hereinafter called APWA.

It is Resources & Development Management Department (RDMD)'s intent to adopt the APWA Standard Plans except where current RDMD Standard Plans, or portions thereof, should be retained on the basis of cost or safety or where portions of RDMD Standard Plans can be used with APWA Standard Plans in a way that meets special RDMD needs and does not adversely affect the benefits of standardization.

There are three categories of Standard Plans:

- 1) RDMD has adopted APWA Standard Plans with or without conditions.
- 2) RDMD has a Standard Plan which addresses a subject but APWA does not.
- 3) APWA has a Standard Plan which addresses a subject but RDMD does not.

This edition of the RDMD Standard Plans includes the first two categories. The third category has not yet been adopted by RDMD. APWA has a number of Standard Plans that have no equivalent RDMD Standard Plans. Although it is intended to consider such Standard Plans for adoption by RDMD, time has precluded a review of such APWA Standard Plans and, therefore, such APWA Standard Plans shall not be used for RDMD projects at this time.

The adopted APWA Standard Plans (with and without conditions) are now included in this edition of RDMD Standard Plans. The APWA Standard Plans are copyrighted and published by Building News, Inc., (10801 National Blvd, Suite 100, Los Angeles, CA 90064; (800)-873-6397). Therefore, RDMD has included the adopted APWA Standard Plans in their entirety without making revisions directly on the APWA Standard Plans. RDMD conditions, if any, are located immediately following the APWA Standard Plans.

Construction plan call-outs should include the appropriate letter prefix: such as "Construct per APWA 312-1" or "Construct per RDMD 1101". Where the call-out omits the letter prefix, the RDMD Standard Plan shall apply unless otherwise directed by the Engineer. Where an APWA Standard Plan is called out which has been approved by RDMD with conditions, the plan call-out as an example would be identified as "RDMD 100-0-OC". In this case, the APWA Standard Plan is given the suffix OC. However, a plan call-out for an APWA Standard Plan shall automatically include the RDMD conditions, if any.

RDMD and APWA Standard Plans may be used by reference, for example, "Construct per RDMD 100-0-OC" or the standard plans may be reproduced on project drawings submitted for RDMD approval. However, where standard plans are reproduced in the drawings, the entire standard plan shall be reproduced. The APWA Standard Plans are copyrighted and may not be reproduced except for use on RDMD plans as noted above.

The users of these Standard Plans should also be aware that the APWA Standard Plans are unsigned. Where Standard Plans (either RDMD or APWA) have been approved by RDMD, RDMD's approval is an approval that the adopted Standard Plan is suitable for general RDMD use. The project proponent, by including the Standard Plans (by reference or reproduction) in project plans, assumes a professional engineer's responsibility for their use.

In addition to the adoption of a portion of APWA Standard Plans, RDMD has also adopted a portion of the Department of Transportation, State of California Standard Plans dated 2002. Due to their availability those Standard Plans are not included in this booklet. The following are the portion of Standard Plans, Department of Transportation, State of California, RDMD has adopted:

1. The portion covering "Signals, Lighting and Electrical Systems."
2. The portion covering "Bridges".
3. Standard Plans A77A through A77N covering "Metal Beam Guard Railing".

The users of the RDMD Standard Plans shall verify Standard Plans for compliance with current ADA requirements.

TABLE OF CONTENTS

APWA STANDARD PLANS

SECTION 1

Street Improvements

112-1-OC	APWA Standard Plan - Curb & Sidewalk Joints
120-1-OC	APWA Standard Plan - Curb & Gutter-Barrier
122-1-OC	APWA Standard Plan - Cross and Longitudinal Gutters
133-1-OC	APWA Standard Plan - Asphalt Concrete Pavement Replacement
140-2-OC	APWA Standard Plan - Median Taper
141-1-OC	APWA Standard Plan - Median Flare

SECTION 3

Flood Control and Storm Drain Facilities

312-2-OC	APWA Standard Plan - Catch Basin Manhole Frame & Cover
----------	--

SECTION 5

Landscaping and Irrigation Systems

500-0	APWA Standard Plan - Landscape Irrigation Symbols
501-1-OC	APWA Standard Plan - Electrical Service
502-1-OC	APWA Standard Plan - Angle Valve
503-1-OC	APWA Standard Plan - Gate Valve
504-1-OC	APWA Standard Plan - Quick Coupler Valve
505-1-OC	APWA Standard Plan - Hose Bibb Valve
506-1-OC	APWA Standard Plan - Remote Control Valve
507-1-OC	APWA Standard Plan - Remote Control Valve with Quick Coupler
508-1-OC	APWA Standard Plan - Thrust Blocks for Plastic Pipe
509-1-OC	APWA Standard Plan - Irrigation Sprinkler Head
510-1-OC	APWA Standard Plan - Vacuum Breaker Assembly
512-1-OC	APWA Standard Plan - Backflow Preventer Assembly (Reduced Pressure Type)
513-1-OC	APWA Standard Plan - Electrical Pull Box
514-1-OC	APWA Standard Plan - Electrical Irrigation Controller
515-1	APWA Standard Plan - Pipe Pinning
516-1-OC	APWA Standard Plan - Security Enclosure
517-1-OC	APWA Standard Plan - Swing Joint Assembly
518-2-OC	APWA Standard Plan - Tree Staking
519-3-OC	APWA Standard Plan - Tree Well
520-2-OC	APWA Standard Plan - Tree Planting
521-1-OC	APWA Standard Plan - Pressure Regulator Installation

APWA STANDARD PLANS (Continued)

SECTION 6

General Facilities

Protective Facilities

600-1-OC APWA Standard Plan - Chain Link Fence and Gates

Retaining Structures

616-1-OC APWA Standard Plan - Reinforced Concrete Retaining Wall Type 7
618-1-OC APWA Standard Plan - Masonry Retaining Wall

Subsurface Access

630-2-OC APWA Standard Plan - 24" Manhole Frame & Cover
633-1-OC APWA Standard Plan - 36" Manhole Frame & Cover
636-1 APWA Standard Plan - Polypropylene Plastic Step

TABLE OF CONTENTS

RDMD STANDARD PLANS

Standard Street Sections

1100	Principal Highway Typical Sections
1101	Major Highway Typical Sections
1102	Major Highway Bridge Sections
1103	Primary Highway Typical Sections
1104	Primary Highway Bridge Sections
1105	Secondary Highway Typical Sections
1106	Secondary Highway Bridge Sections
1107	Other Street Improvements
1108	Rural Secondary Highway Typical Sections
1109	Rural Local Street Typical Section
1110	Rural Local Street Typical Section
1111	Sidewalk Returns & Curb Radius
1112	Standard Knuckle
1113	Standard Cul-De-Sac (Symmetrical and Unsymmetrical Pkwy.)
1114	Landscaped Median Typical Section
1115	Curb Ramp
1117	Intersection Sight Distance
1118	Left-Turn-In Only Median Opening
1119	Raised Median Nose Location
1120	Bus Turnouts

Curb, Sidewalk, Apron, Gutter and Mailbox Details

1201	Concrete Rolled Curb, Private Street
1205	Sidewalk Details
1206	Alley Intersection
1208	Special Cross Gutter (Steep Grades)
1209	Depressed Curb Driveway Approach
1210	Flared Depressed Curb Driveway Approach
1211	Single Unit Mailbox Detail
1212	Multi Unit Mailbox Detail

Grading and Drainage Details

1301	Inlet Type I
1302	Inlet Type II
1303	Inlet Type III
1304	Inlet Type IV
1305	Inlet Type V
1306	Miscellaneous Curb Inlet Details and Notes
1307	Miscellaneous Inlet Details and Notes
1308	Local Depression
1309	Parkway Culvert - Type "A", "B" & "C"

RDMD STANDARD PLANS (Continued)

Grading and Drainage Details (Cont'd)

1310	Junction Structure - Type I
1311	Junction Structure - Type II
1312	Junction Structure - Type III
1313	Junction Structure - Type IV
1314	Junction Structure - Type V
1315	Junction Structure - Type VI
1317	Reinforced Concrete Collar-Notes
1318	Transverse Joint Details
1319	Reinforced Concrete Pipe - Bedding Detail
1320	Hillside Lot and Common Sideyard Drainage
1321	Terrace and Down Drain
1322	Benching for Compacted Fill
1323	Canyon Subdrain
1324	Culvert Debris Wall
1325	Channel Weepholes
1326	Pipe Entrance to Earth Channel
1327	Desilting Basin
1328	Sandbag Velocity Reducer
1329	Street Desilting Basin - Vehicle Access Ramp
1330	Temporary Drainage Inlet
1331	Downdrain to Pipe Transition
1332	Interceptor Drain
1333	Concrete Pipe Slope Anchor
1334	Overside Drains

Signs, Barricades, Monuments, Lighting Details & Fencing

1401	Dead End & Widened Section Signing
1402	Markers
1404	Timber Barricade - Type III
1405	Survey Monument Type "A"
1406	Survey Monument Type "B"
1407	Special Provisions - Street Name Sign
1408	Advance Street Name Sign
1409	Traffic Sign Placement
1410	Parkway Obstruction
1411	Street Lighting
1413	Guard Cable Fence
1414	6' Block Wall - 6" Block
1415	6' Block Wall - 4" Block/Pilaster
1416	Crosswalk Detail
1417	Sign Post Installation
1418	Project Information Sign
1419	Road/Trail Closure Sign

RDMD STANDARD PLANS (Continued)

Manhole Details

1501	Non-Reinforced Concrete Concentric Cone Manhole
1502	Non-Reinforced Concrete Eccentric Cone Manhole
1503	36" Reinforced Concrete Manhole
1504	48" Reinforced Concrete Manhole
1505	Flat Top Manhole Covers
1506	Reinforced Concrete Box Manhole
1507	Manhole Steps
1508	Deep Manhole Landings

Standard Park Details

1601	Park Security Light
1602	Buried Electrical Wiring on Park Property
1603	Security Enclosure
1611	Picnic Table Slab
1612	Trash Receptacle Installation
1613	Drinking Fountain and Sump
1621	Asphalt and Concrete Walks
1631	Play Lot Drain
1641	Sign Footing
1682	Header Details
1685	Mow Strip
1690	Baseball Diamond Drainage Patterns
1692	Parking Meter Installation

Landscape and Irrigation Details

1700	Street Tree List
1701	Drought Tolerant Plants
1705	Protective Staking
1708	Tree Root Barrier
1753	Rotary Pop-Up Head
1760	Irrigation Line Trenching

Notes, Special Provisions and Miscellaneous Details

1801	Spec. Prov. - General Notes
1802	Spec. Prov. - Lime Treated Soil
1803	Spec. Prov. - Portland Cement Concrete
1804	Spec. Prov. - Untreated Base Materials
1805	Spec. Prov. - Asphalt Concrete
1806	Spec. Prov. - Earthwork
1807	Spec. Prov. - Concrete Median Paving
1808	Spec. Prov. - Geotextiles
1809	Spec. Prov. - Stonework

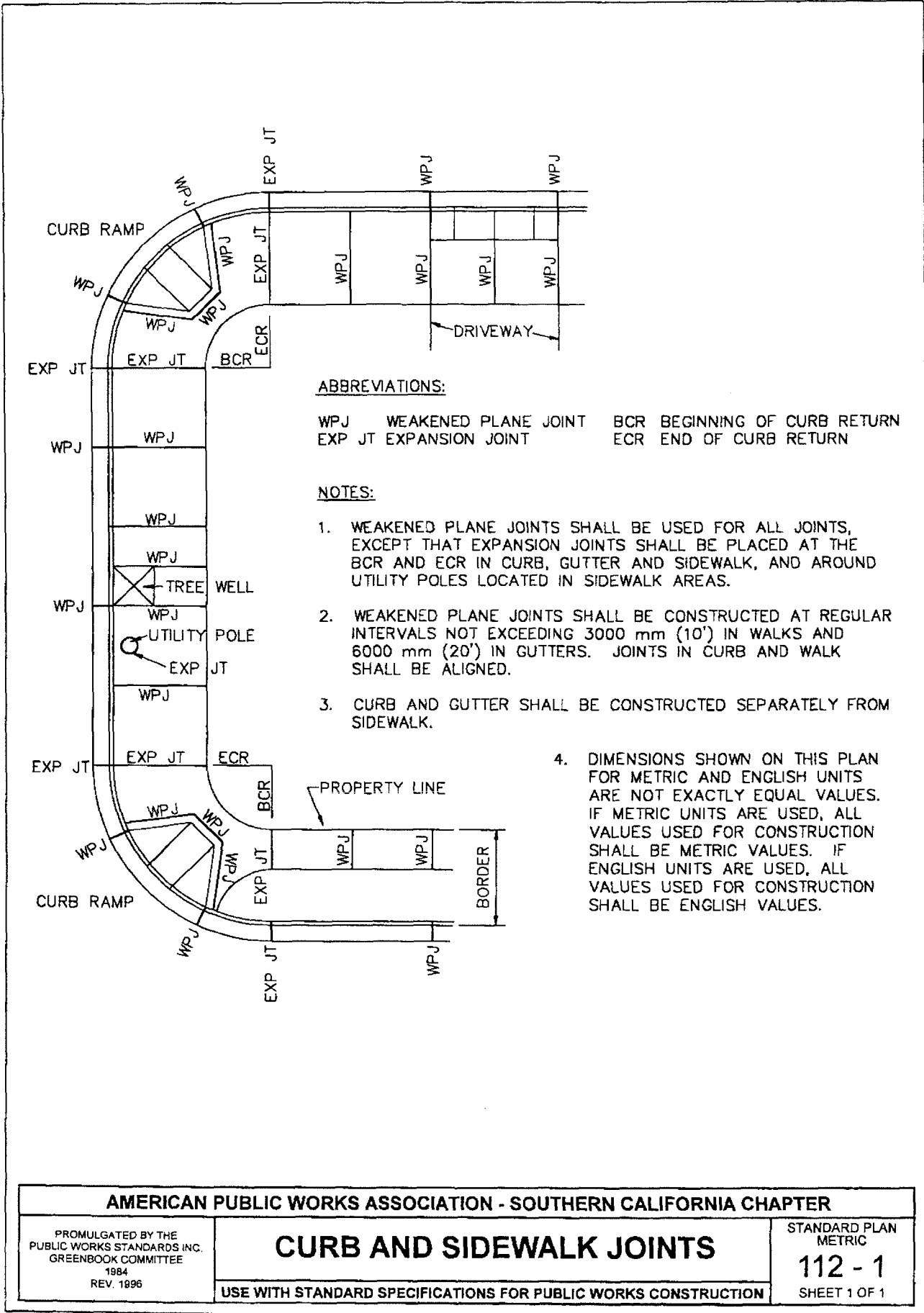

AMERICAN PUBLIC WORKS ASSOCIATION - SOUTHERN CALIFORNIA CHAPTER		
PROMULGATED BY THE PUBLIC WORKS STANDARDS INC. GREENBOOK COMMITTEE 1984 REV. 1996	<h2 style="margin: 0;">CURB AND SIDEWALK JOINTS</h2>	STANDARD PLAN METRIC <h1 style="margin: 0;">112 - 1</h1>
USE WITH STANDARD SPECIFICATIONS FOR PUBLIC WORKS CONSTRUCTION		SHEET 1 OF 1

SEE RDMD STANDARD PLAN 112-1-OC FOR CONDITIONS

The following Standard Plans for Public Works Construction, 1997 Edition, of the American Public Works Association (Southern California Chapter) and Associated General Contractors of California (Southern California Districts) have been adopted by Orange County Resources & Development Management Department (RDMD) with conditions which shall apply to RDMD use. The conditions are listed below.

<u>APWA #</u>	<u>RDMD #</u>	<u>Name and Conditions</u>
112-1	112-1-0C	<u>Curb and Sidewalk Joints</u>

1. Weakened plane joints (WPJ) shall be constructed in curb and gutters not to exceed 10 feet (3m).
2. WPJ shall be a depth of 1/4" (6mm) to 1/3" (8mm) of the concrete thickness.
3. Expansion joint (Exp JT) shall be full depth.
4. a. Sidewalk:
WPJ shall be quickjoints and finished with a butterfly tool (R=1/8" (3mm))
- b. Formed Curb and Gutter:
Exp JT shall be 1/4" (6mm) thick premolded filler (asphalt saturated fiber) in the top of curb, face of curb and across the gutter, as required by the Engineer.
- c. Extruded Curb and Gutter:
Exp JT shall be cut (hand tooled) in the top of curb, face of curb, and across the gutter or sawcut (within 24 hours).
- d. Gutter Transition:
Exp JT shall 1/4" (6mm) thick premolded filler, as required by the Engineer.
5. No WPJ or monolithic concrete placement shall be allowed between driveways and sidewalk, sidewalk and driveway approach, driveway approach and curb, or curb and sidewalk.
6. Meter boxes and vaults shall have WPJ similar to tree well detail.
7. Premolded Filler (1/4" (6mm) thick asphalt saturated fiber) shall be placed between sidewalk return and curb (see S.P. IIII).

ORANGE COUNTY RESOURCES & DEVELOPMENT MANAGEMENT DEPARTMENT

Approved

H. I. Nakasone
H. I. Nakasone, Chief Engineer

Adopted: Res. 91-1481

Revised: Res. 96-546; 06-010

STD. PLAN

112-1-0C

APWA STANDARD PLANS - CURB & SIDEWALK JOINTS

SHT. 1 OF 1

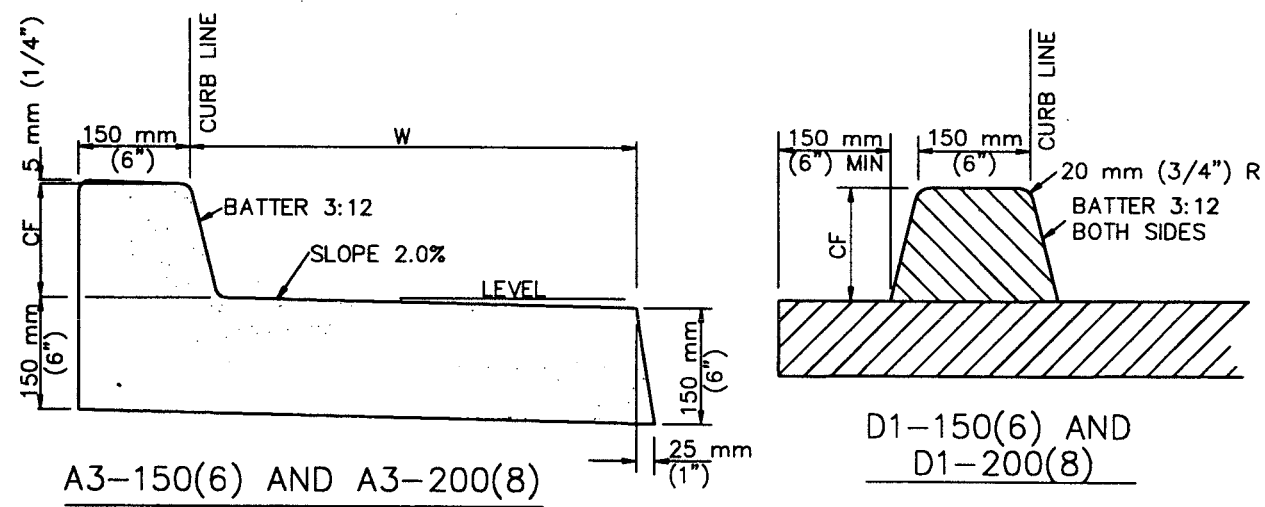
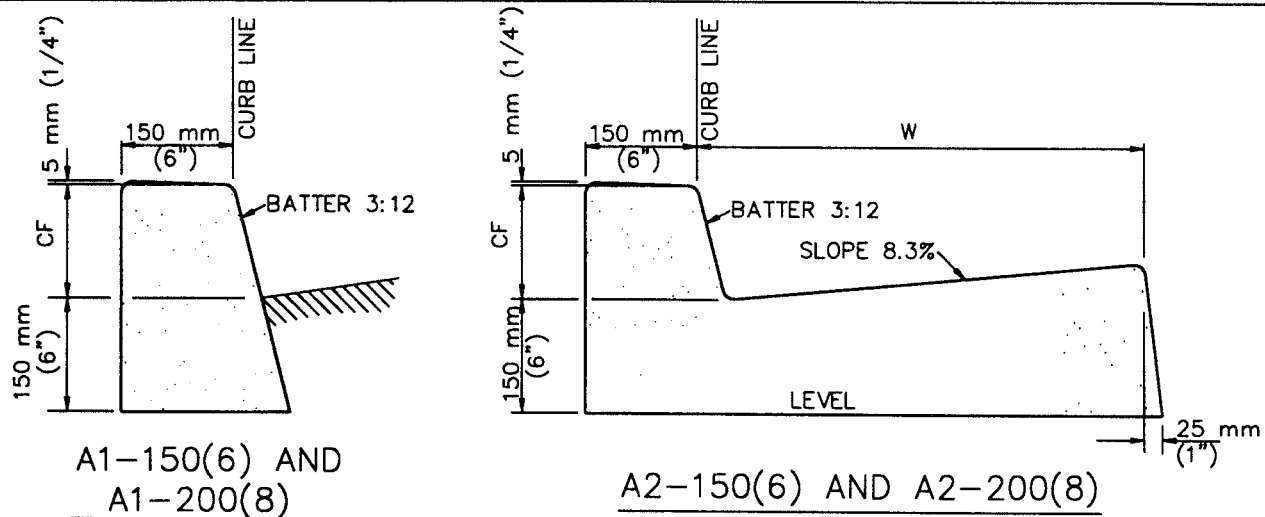

NOTES:

1. THE LAST NUMBER IN THE DESIGNATION IS THE CURB FACE (CF) HEIGHT, mm (INCHES).
2. GUTTER WIDTH, W, IS 600 mm (24") UNLESS OTHERWISE SPECIFIED.
3. TYPES A1, A2, A3 AND C1 SHALL BE CONSTRUCTED FROM PCC.
4. TYPE D1 CURB SHALL BE CONSTRUCTED FROM ASPHALT CONCRETE.
5. TYPE C1 CURB SHALL BE ANCHORED WITH STEEL DOWELS AS SHOWN OR WITH AN EPOXY APPROVED BY THE ENGINEER.
6. ALL EXPOSED CORNERS ON PCC CURBS AND GUTTERS SHALL BE ROUNDED WITH A 15 mm (1/2") RADIUS.
7. DIMENSIONS SHOWN ON THIS PLAN FOR METRIC AND ENGLISH UNITS ARE NOT EXACTLY EQUAL VALUES. USE EITHER METRIC OR ENGLISH VALUES, AS REQUIRED, BUT NOT BOTH, EXCEPT THAT ASTM 615 REINFORCING STEEL MAY BE SUBSTITUTED FOR ASTM 615M STEEL.

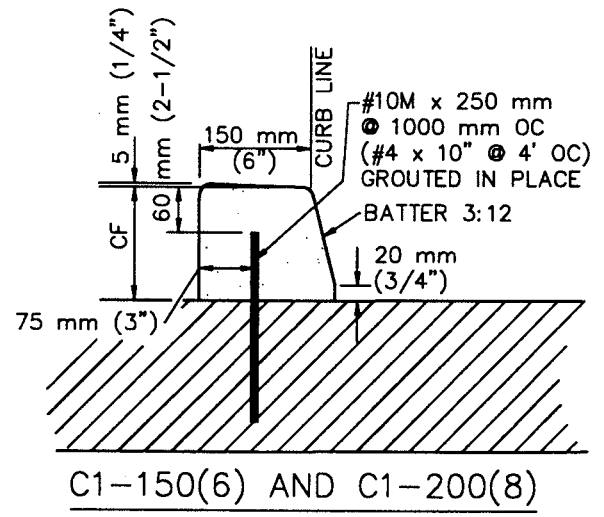

AMERICAN PUBLIC WORKS ASSOCIATION - SOUTHERN CALIFORNIA CHAPTER		
PROMULGATED BY THE PUBLIC WORKS STANDARDS INC. GREENBOOK COMMITTEE 1984 REV. 1996	<h2 style="margin: 0;">CURB AND GUTTER — BARRIER</h2>	STANDARD PLAN METRIC <h1 style="margin: 0;">120 - 1</h1> SHEET 1 OF 1
USE WITH STANDARD SPECIFICATIONS FOR PUBLIC WORKS CONSTRUCTION		

SEE RDMD STANDARD PLAN 120-1-OC FOR CONDITIONS

The following Standard Plans for Public Works Construction, 1997 Edition, of the American Public Works Association (Southern California Chapter) and Associated General Contractors of California (Southern California Districts) have been adopted by the Orange County Resources & Development Management Department (RDMD) with conditions which shall apply to RDMD use. The conditions are listed below.

APWA # RDMD # Name and Conditions

120-1 120-1-0C Curb and Gutter-Barrier

1. Type A-2. Place asphalt concrete surfacing $\frac{3}{8}$ " (9mm) above P.C.C. gutter.
2. Type D-1. Tack A.C. pavement with emulsified asphalt at rate of 0.05 gallon/square yard (0.23 liters/square meter) prior to placing A.C. curb. Alternate D1 curb may be constructed using a batter of 6:12 and 5" (125mm) top width as shown below .

3. TABLE OF CURB TYPE AND W FOR USE WITH RDMD STANDARD ROADWAY TYPICAL SECTION

STD 120-1	"W"
A3-200(8)	1'
A2-200(8)	2'
A2-150(6)	1'-6"

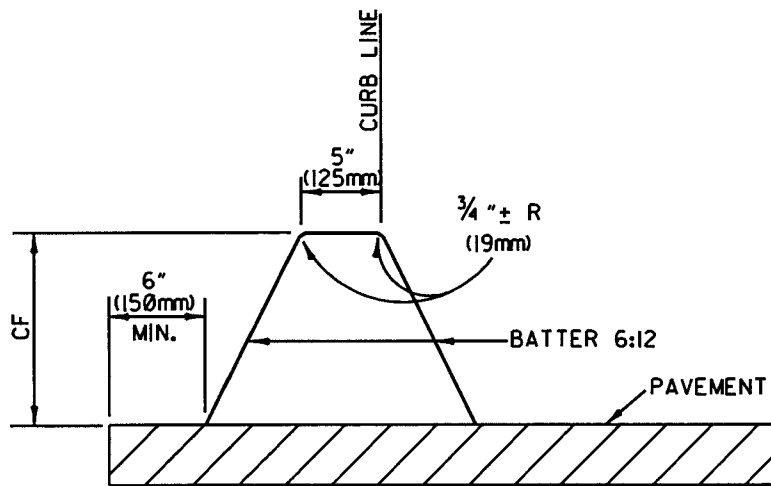

ALTERNATE D1-150(6) & D1-200(8)

ORANGE COUNTY RESOURCES & DEVELOPMENT MANAGEMENT DEPARTMENT

Approved

H. I. Nakasone
H. I. Nakasone, Chief Engineer

Adopted: Res. 91-1481 Revised: Res. 96-546; 06-010

STD. PLAN

120-1-0C

APWA STANDARD PLAN - CURB AND GUTTER-BARRIER

SHT. 1 OF 1

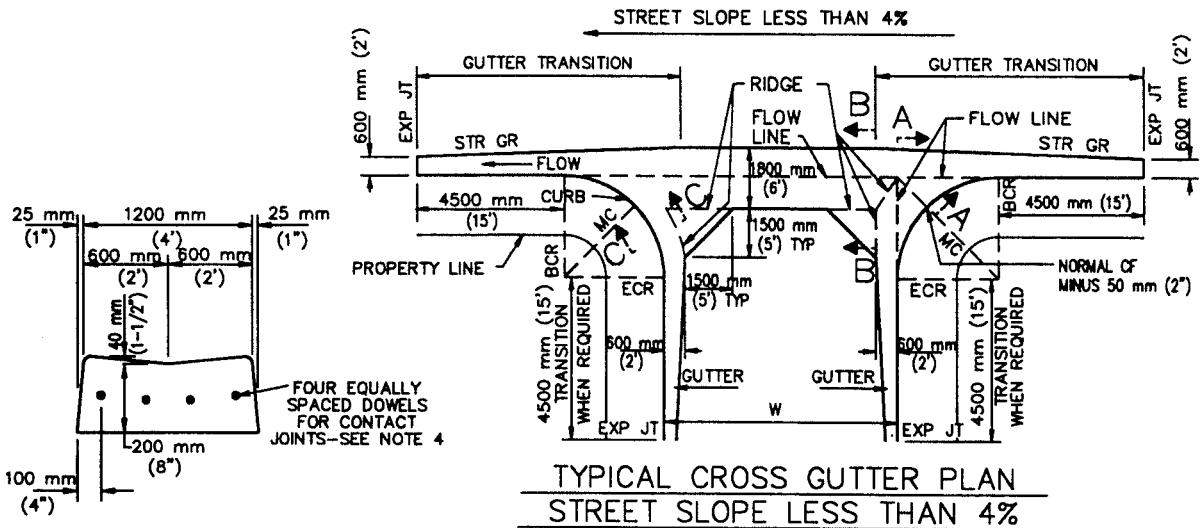

TYPICAL CROSS GUTTER PLAN
STREET SLOPE LESS THAN 4%

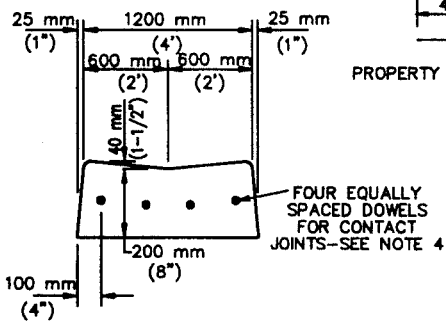

LONGITUDINAL
GUTTER

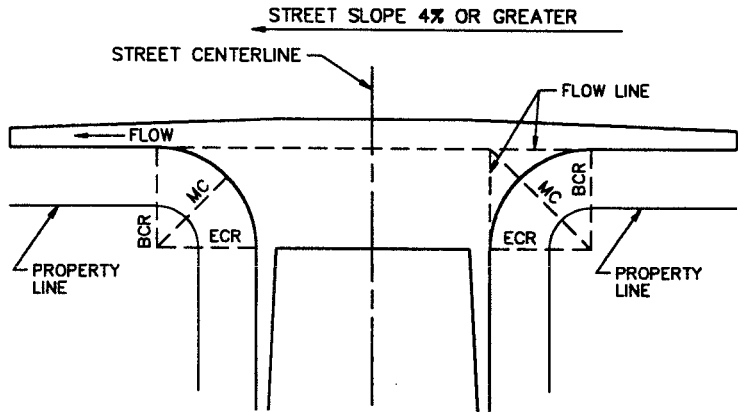

TYPICAL CROSS GUTTER PLAN
STREET SLOPE MORE THAN 4%

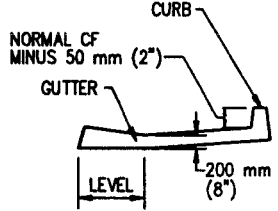

SECTION A-A

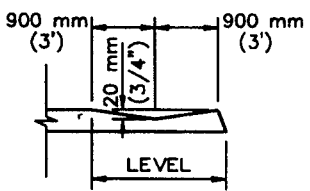

SECTION B-B

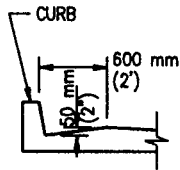

SECTION C-C

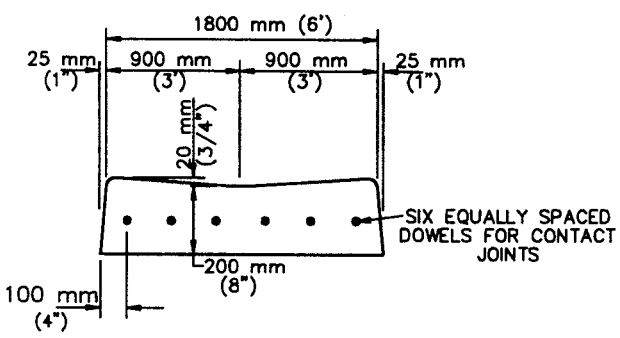

SECTION D-D

AMERICAN PUBLIC WORKS ASSOCIATION - SOUTHERN CALIFORNIA CHAPTER		
PROMULGATED BY THE PUBLIC WORKS STANDARDS INC. GREENBOOK COMMITTEE 1984 REV. 1996	<h2 style="margin: 0;">CROSS AND LONGITUDINAL GUTTERS</h2> <p style="margin: 0;">USE WITH STANDARD SPECIFICATIONS FOR PUBLIC WORKS CONSTRUCTION</p>	STANDARD PLAN METRIC <h1 style="margin: 0;">122 - 1</h1> SHEET 1 OF 2

SEE RDMD STANDARD PLAN 122-1-OC FOR CONDITIONS

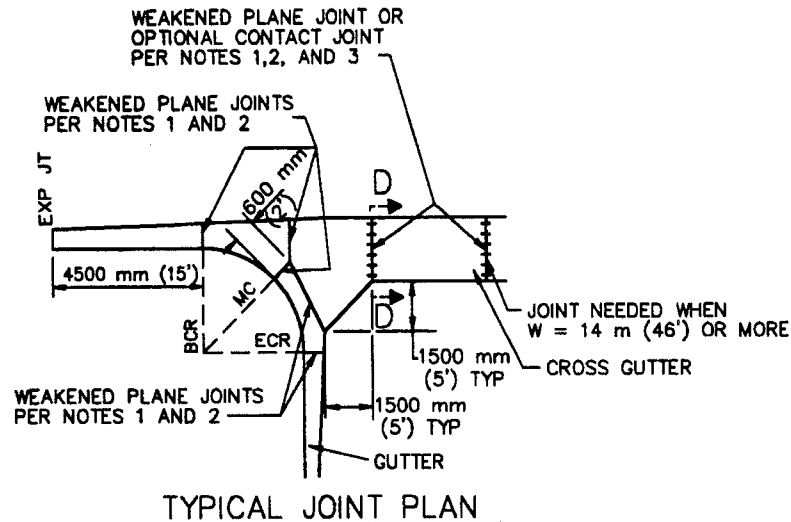

NOTES:

1. WEAKENED PLANE AND/OR CONTACT JOINTS SHALL BE PLACED IN CURB AND GUTTER AT LOCATIONS SHOWN ON THE TYPICAL JOINT PLAN HEREON.
2. WEAKENED PLANE JOINTS SHALL BE PLASTIC CONTROL JOINTS OR 40 mm (1-1/2") DEEP SAW CUTS. CONCRETE SAWING SHALL TAKE PLACE WITHIN 24 HOURS AFTER CONCRETE IS PLACED.
3. DOWELS FOR CONTACT JOINTS SHALL BE #15M BARS 450 mm LONG (#4 BARS 18" LONG).
4. PLACE A WEAKENED PLANE OR CONTACT JOINT WHERE LONGITUDINAL ALLEY GUTTER JOINS CONCRETE ALLEY INTERSECTION.
5. ALL EXPOSED CORNERS ON PCC GUTTERS SHALL BE ROUNDED WITH 15 mm (1/2") RADIUS.
6. CONCRETE SHALL BE INTEGRAL WITH CURB UNLESS OTHERWISE SPECIFIED.
7. DIMENSIONS SHOWN ON THIS PLAN FOR METRIC AND ENGLISH UNITS ARE NOT EXACTLY EQUAL VALUES. IF METRIC UNITS ARE USED, ALL VALUES USED FOR CONSTRUCTION SHALL BE METRIC VALUES. IF ENGLISH UNITS ARE USED, ALL VALUES USED FOR CONSTRUCTION SHALL BE ENGLISH VALUES. HOWEVER, ASTM 615 REINFORCING STEEL MAY BE SUBSTITUTED FOR ASTM 615M STEEL.

AMERICAN PUBLIC WORKS ASSOCIATION - SOUTHERN CALIFORNIA CHAPTER

STANDARD PLAN
METRIC

CROSS AND LONGITUDINAL GUTTERS

122 - 1
SHEET 2 OF 2

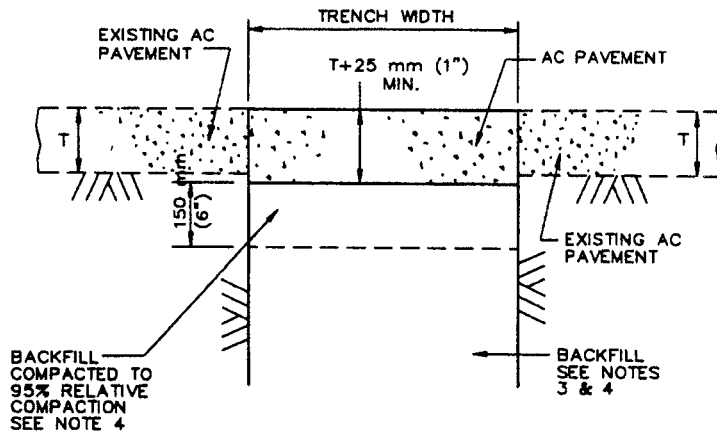

CASE I: (WITHOUT BASE)

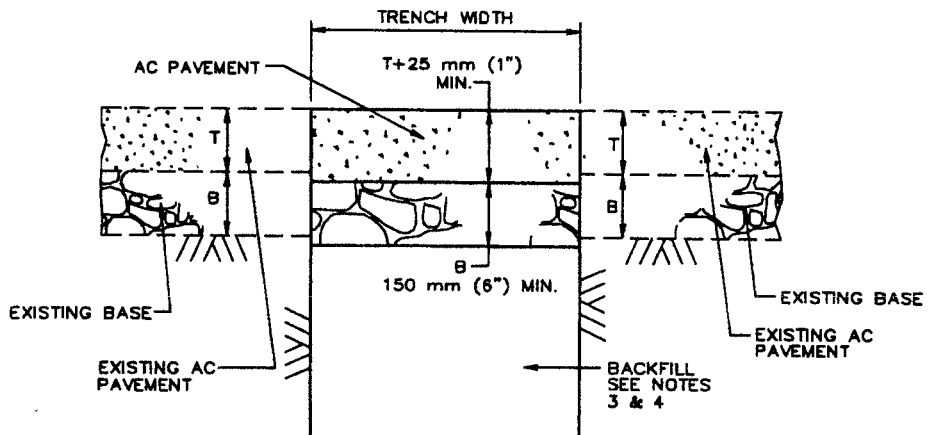

CASE II: (WITH BASE)

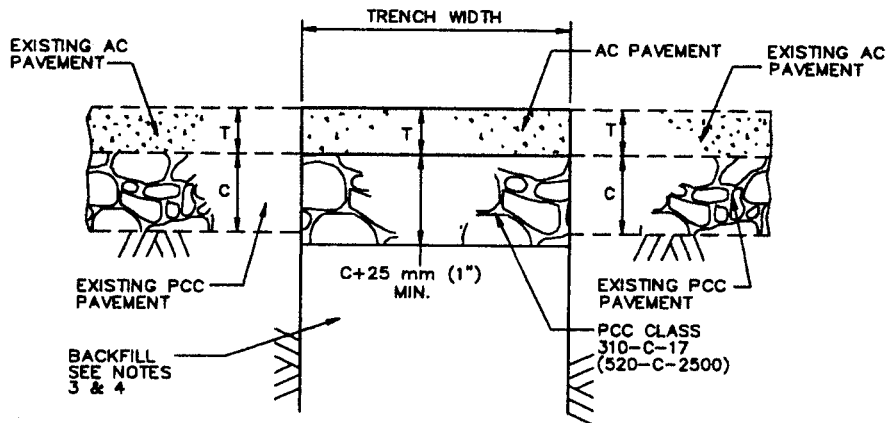

CASE III: (WITH AC PVMT ON PCC PVMT)

AMERICAN PUBLIC WORKS ASSOCIATION - SOUTHERN CALIFORNIA CHAPTER		
PROMULGATED BY THE PUBLIC WORKS STANDARDS INC. GREENBOOK COMMITTEE 1993 REV. 1996	<h2 style="margin: 0;">ASPHALT CONCRETE PAVEMENT REPLACEMENT</h2>	STANDARD PLAN METRIC <h1 style="margin: 0;">133 - 1</h1> SHEET 1 OF 2
USE WITH STANDARD SPECIFICATIONS FOR PUBLIC WORKS CONSTRUCTION		

SEE RDMD STANDARD PLAN 133-1-OC FOR CONDITIONS

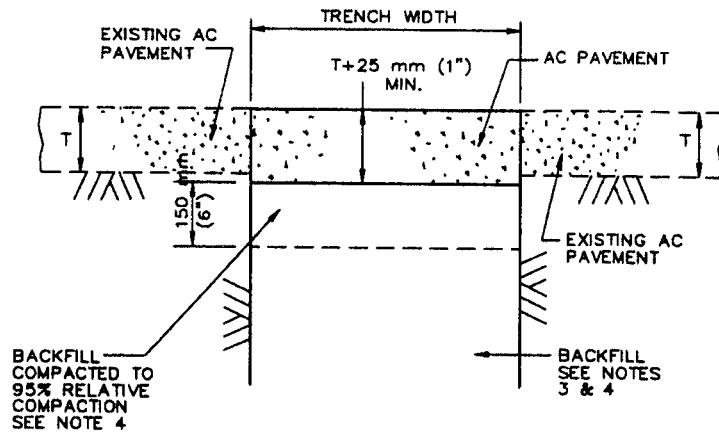

CASE I: (WITHOUT BASE)

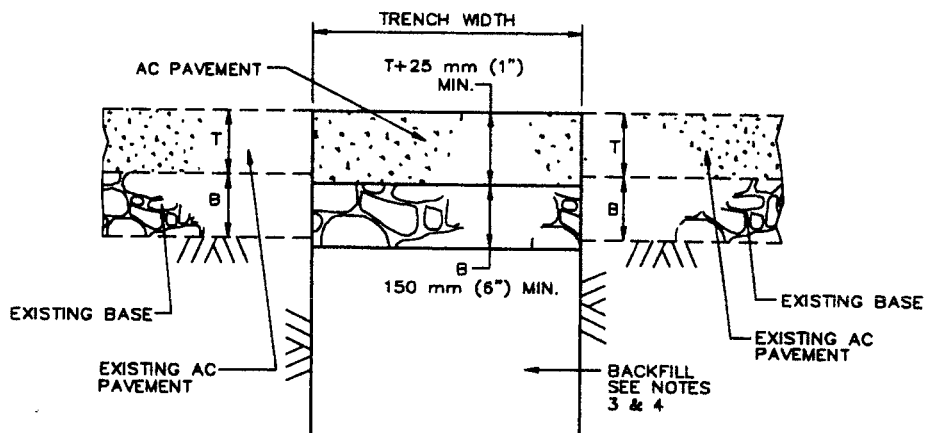

CASE II: (WITH BASE)

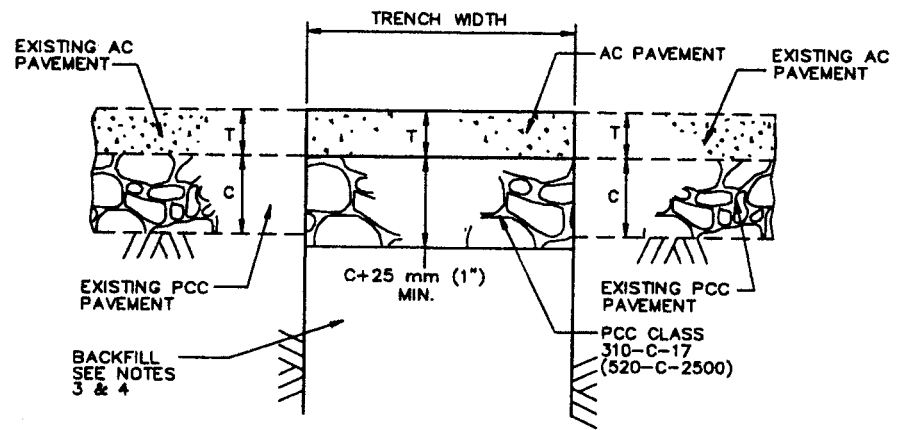

CASE III: (WITH AC PVMT ON PCC PVMT)

AMERICAN PUBLIC WORKS ASSOCIATION - SOUTHERN CALIFORNIA CHAPTER		
PROMULGATED BY THE PUBLIC WORKS STANDARDS INC. GREENBOOK COMMITTEE 1983 REV. 1996	<h1>ASPHALT CONCRETE PAVEMENT REPLACEMENT</h1>	STANDARD PLAN METRIC <h2>133 - 1</h2> SHEET 1 OF 2
USE WITH STANDARD SPECIFICATIONS FOR PUBLIC WORKS CONSTRUCTION		

SEE RDMD STANDARD PLAN 133-1-OC FOR CONDITIONS

NOTES:

1. ALL PAVEMENT REMOVALS SHALL BE MADE ON STRAIGHT LINE SAW CUTS A MINIMUM OF 40 mm (1-1/2") DEEP. IF CUT LINE IS LESS THAN 900 mm (36") FROM A CUT LINE, EXPANSION JOINT OR EDGE, THE EXISTING PAVEMENT SHALL BE REMOVED TO CUT LINES, EXPANSION JOINT OR EDGE OR AS DIRECTED BY THE ENGINEER.
2. DURING EXCAVATION AND SUBGRADE PREPARATION, THE CONTRACTOR SHALL TAKE ALL NECESSARY STEPS TO ENSURE THE PROTECTION OF ALL IMPROVEMENTS, WHETHER PUBLIC OR PRIVATE, INCLUDING UTILITIES AND THEIR SERVICES, FROM ANY DAMAGE THAT COULD OCCUR DUE TO CONTRACTOR'S OPERATION.
3. BACKFILL AND DENSIFICATION SHALL BE DONE IN CONFORMANCE WITH SUBSECTION 306-1.3 OF THE STANDARD SPECIFICATIONS, EXCEPT AS FOLLOWS:
 - A) TRENCH BACKFILL SHALL BE DENSIFIED TO A MINIMUM OF 90 PERCENT RELATIVE COMPACTION.
 - B) WHEN PAVEMENT IS TO BE PLACED DIRECTLY ON SUBGRADE MATERIAL, THE TOP 150 mm (6") OF SUBGRADE MATERIAL SHALL BE COMPACTED TO A RELATIVE COMPACTION OF 95 PERCENT.
4. CLASS 60-E-1 (100-E-100) SAND SLURRY BACKFILL MAY BE REQUIRED BY THE AGENCY.
5. TEMPORARY PAVEMENT REPLACEMENT SHALL BE PLACED AT THE CONTRACTOR'S EXPENSE, UNLESS OTHERWISE SPECIFIED BY THE ENGINEER. IT SHALL BE PLACED LEVEL WITH THE EXISTING PAVEMENT ON COMPACTED TRENCH BACKFILL AND SHALL BE A MINIMUM OF 50 mm (2") THICK.
6. PERMANENT PAVEMENT RESURFACING SHALL BE DONE WITHIN TWO (2) WEEKS AFTER BACKFILLING OF TRENCHES HAS BEEN COMPLETED, AND ONLY AFTER SETTLEMENT HAS TAKEN PLACE AND THE FILL SURFACE HAS SUFFICIENTLY DRIED. ALL CUTS SHALL BE CLEAN AND STRAIGHT.
7. CONTACT SURFACES OF EXISTING PAVEMENT, MANHOLES FRAMES AND SHAFTS AND CONCRETE SURFACES SHALL BE GIVEN A TACK COAT BEFORE PERMANENT ASPHALT TRENCH RESURFACING IS PLACED.
8. ASPHALT CONCRETE PAVEMENT SHALL BE D1-AR-4000.
9. DIMENSIONS SHOWN ON THIS PLAN FOR METRIC AND ENGLISH UNITS ARE NOT EXACTLY EQUAL VALUES. IF METRIC UNITS ARE USED, ALL VALUES USED FOR CONSTRUCTION SHALL BE METRIC VALUES. IF ENGLISH UNITS ARE USED, ALL VALUES USED FOR CONSTRUCTION SHALL BE ENGLISH VALUES.

AMERICAN PUBLIC WORKS ASSOCIATION - SOUTHERN CALIFORNIA CHAPTER

ASPHALT CONCRETE PAVEMENT REPLACEMENT

STANDARD PLAN
METRIC

133 - 1
SHEET 2 OF 2

SEE RDMD STANDARD PLAN 133-1-OC FOR CONDITIONS

The following Standard Plans for Public Works Construction, 1997 Edition, of the American Public Works Association (Southern California Chapter) and Associated General Contractors of California (Southern California Districts) have been adopted by Orange County Resources & Development Management Department (RDMD) with conditions which shall apply to RDMD use. The conditions are listed below.

APWA # RDMD # Name and Conditions

133-1 133-1-0C Asphalt Concrete Pavement Replacement

1. Delete Notes 4 and 8 of APWA Standard Plan 133-1.
2. Pavement replacement shall be "T-cut" to extend 12" (300 mm) beyond each side of trench width. Pavement removal in the area of additional width shall be by cold plane or other method approved by the Engineer. Depth of removal shall be at least 0.15' (45 mm) on arterial highways and at least 0.12' (36 mm) elsewhere.
3. Full travel lane replacement or grinding with at least 0.15' (45 mm) cap is required on all arterial highways in accordance with Section 6-3-60 (d) of the Orange County Codified Ordinance.
4. Full travel lane replacement or grinding with at least 0.12' (36 mm) cap is required on any street if the existing surface course has been in place for less than 2 years.
5. Surface course and base course asphalt concrete pavement shall be of the same mix as the existing asphalt concrete pavement(s) unless otherwise approved by the Engineer.

ORANGE COUNTY RESOURCES & DEVELOPMENT MANAGEMENT DEPARTMENT

Approved

H. I. Nakasone
H. I. Nakasone, Chief Engineer

Adopted: Res. 04-095 Revised: Res. 06-010

STD. PLAN

133-1-0C

APWA STANDARD PLAN - ASPHALT CONCRETE PAVEMENT REPLACEMENT

SHT. 1 OF 1

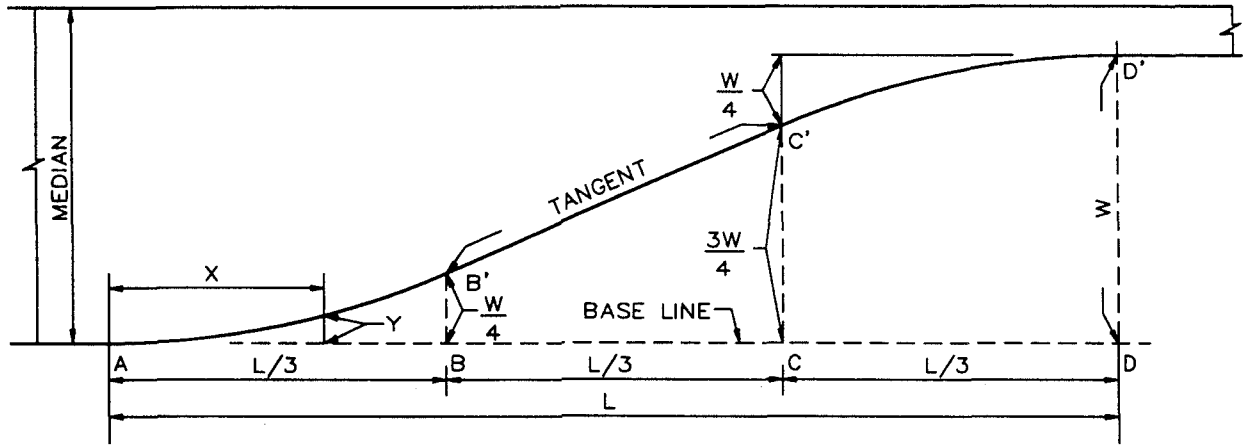

$$Y = 2.25W \left(\frac{X}{L} \right)^2$$

L=LENGTH OF TAPER
W=MAXIMUM OFFSET DISTANCE
X=DISTANCE ALONG BASE LINE
Y=OFFSET FROM BASE LINE

L, m	DISTANCE X, L/12 INCREMENTS, m											
18.00 (60')	1.50 (5')	3.00 (10')	4.50 (15')	6.00 (20')	7.50 (25')	9.00 (30')	10.50 (35')	12.00 (40')	13.50 (45')	15.00 (50')	16.50 (55')	18.00 (60')
21.60 (72')	1.80 (6')	3.60 (12')	5.40 (18')	7.20 (24')	9.00 (30')	10.80 (36')	12.60 (42')	14.40 (48')	16.20 (54')	18.00 (60')	19.80 (66')	21.60 (72')
27.00 (90')	2.25 (7.5')	4.50 (15')	6.75 (22.5')	9.00 (30')	11.25 (37.5')	13.50 (45')	15.75 (52.5')	18.00 (60')	20.25 (67.5')	22.50 (75')	24.75 (82.5')	27.00 (90')
36.00 (120')	3.00 (10')	6.00 (20')	9.00 (30')	12.00 (40')	15.00 (50')	18.00 (60')	21.00 (70')	24.00 (80')	27.00 (90')	30.00 (100')	33.00 (110')	36.00 (120')
45.00 (150')	3.75 (12.5')	7.50 (25')	11.25 (37.5')	15.00 (50')	18.75 (62.5')	22.50 (75')	26.25 (87.5')	30.00 (100')	33.75 (112.5')	37.50 (125')	41.25 (137.5')	45.00 (150')
W, mm	OFFSET Y, mm											
3000 (10')	47 (0.16')	188 (0.62')	422 (1.41')	750 (2.50')	1125 (3.75')	1500 (5.00')	1875 (6.25')	2250 (7.50')	2578 (8.59')	2812 (9.38')	2953 (9.84')	3000 (10.00')
3300 (11')	51 (0.17')	206 (0.69')	464 (1.55')	825 (2.75')	1238 (4.13')	1650 (5.50')	2063 (6.88')	2475 (8.25')	2836 (9.45')	3094 (10.31')	3249 (10.83')	3300 (11.00')
3600 (12')	56 (0.19')	225 (0.75')	506 (1.69')	900 (3.00')	1350 (4.50')	1800 (6.00')	2250 (7.50')	2700 (9.00')	3094 (10.31')	3375 (11.25')	3544 (11.81')	3600 (12.00')
5700 (19')	89 (0.30')	356 (1.19')	802 (2.67')	1425 (4.75')	2138 (7.13')	2850 (9.50')	3562 (11.88')	4275 (14.25')	4898 (16.33')	5344 (17.81')	5611 (18.70')	5700 (19.00')
6000 (20')	94 (0.31')	375 (1.25')	844 (2.81')	1500 (5.00')	2250 (7.50')	3000 (10.00')	3750 (12.50')	4500 (15.00')	5156 (17.19')	5625 (18.75')	5906 (19.69')	6000 (20.00')
6300 (21')	98 (0.33')	394 (1.31')	886 (2.95')	1575 (5.25')	2363 (7.88')	3150 (10.50')	3937 (13.13')	4725 (15.75')	5414 (18.05')	5906 (19.69')	6202 (20.67')	6300 (21.00')
6600 (22')	103 (0.34')	412 (1.38')	928 (3.09')	1650 (5.50')	2475 (8.25')	3300 (11.00')	4125 (13.75')	4950 (16.50')	5672 (18.91')	6188 (20.62')	6497 (21.66')	6600 (22.00')

NOTES:

TO DETERMINE OFFSET DISTANCE FOR ANY LENGTH OF TAPER USE THE FORMULA $Y = 2.25W \left(\frac{X}{L} \right)^2$ FOR THE PORTIONS AB' AND C'D' WHICH ARE PARABOLIC CURVES. THE PORTION B'C' IS A TANGENT. WHEN THE BASE LINE IS CURVED, THE OFFSETS ARE APPLIED TO THE CURVED BASE LINE, AND B'C' IS NO LONGER A TANGENT.

DIMENSIONS SHOWN ON THIS PLAN FOR METRIC AND ENGLISH UNITS ARE NOT EXACTLY EQUAL VALUES. IF METRIC UNITS ARE USED, ALL VALUES USED FOR CONSTRUCTION SHALL BE METRIC VALUES. IF ENGLISH UNITS ARE USED, ALL VALUES USED FOR CONSTRUCTION SHALL BE ENGLISH VALUES.

AMERICAN PUBLIC WORKS ASSOCIATION - SOUTHERN CALIFORNIA CHAPTER		
PROMULGATED BY THE PUBLIC WORKS STANDARDS INC. GREENBOOK COMMITTEE 1984 REV. 1992, 1996	<h2 style="margin: 0;">MEDIAN TAPER</h2>	STANDARD PLAN METRIC <h1 style="margin: 0;">140 - 2</h1>
USE WITH STANDARD SPECIFICATIONS FOR PUBLIC WORKS CONSTRUCTION		SHEET 1 OF 1

SEE RDMD STANDARD PLAN 140-2-OC FOR CONDITIONS

The following Standard Plans for Public Works Construction, 1997 Edition of the American Public Works Association (Southern California Chapter) and Associated General Contractors of California (Southern California Districts) have been adopted by the Orange County Resources & Development Management Department (RDMD) with conditions which shall apply to RDMD use. The conditions are listed below.

APWA # RDMD # Name and Conditions
 140-2 140-2-0C Median Taper

1. 90' (27.00m) for single left turn pocket and 150' (45.00m) for a dual left turn pocket. For L=150' W=20'

DIST. X (m)	10' (3.00)	20' (6.00)	30' (9.00)	40' (12.00)	50' (15.00)	60' (18.00)	70' (21.00)	80' (24.00)	90' (27.00)	100' (30.00)	110' (33.00)	120' (36.00)	130' (39.00)	140' (42.00)	150' (45.00)
OFFSET Y (mm)	0.20' (60)	0.80' (240)	1.80' (540)	3.20' (960)	5.00' (1500)	7.00' (2100)	9.00' (2700)	11.00' (3300)	13.00' (3900)	15.00' (4500)	16.80' (5040)	18.20' (5460)	19.20' (5760)	19.80' (5940)	20.00' (6000)

Dimensions shown on this plan for English and Metric Units are not exactly equal values. If English units are used all values used for construction shall be English values. If Metric units are used all values used for construction shall be Metric values.

ORANGE COUNTY RESOURCES & DEVELOPMENT MANAGEMENT DEPARTMENT

Approved

H. I. Nakasone
 H. I. Nakasone, Chief Engineer

Adopted: Res. 91-1481

Revised: Res. 96-546; 06-010

STD. PLAN

140-2-0C

APWA STANDARD PLAN - MEDIAN TAPER

SHT. 1 OF 1

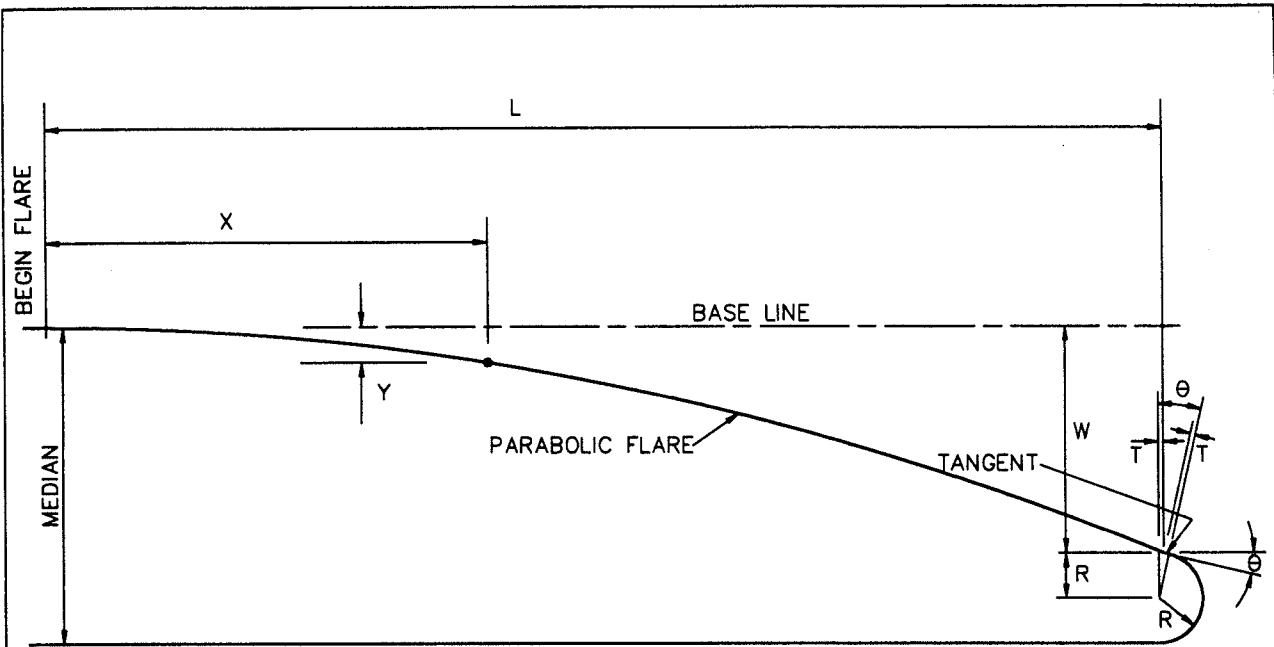

- L = LENGTH OF FLARE
- W = MAXIMUM OFFSET DISTANCE
- X = DISTANCE ALONG BASE LINE
- Y = OFFSET FROM BASE LINE
- T = TANGENT LENGTH
- R = RADIUS OF NOSE
- θ = MAXIMUM FLARE DEFLECTION ANGLE

$$Y = W \left(\frac{X}{L} \right)^2$$

$$\tan \theta = \frac{2W}{L}$$

$$T = R \tan \frac{\theta}{2}$$

IF STATION OF RADIUS POINT IS NOT GIVEN ON PLAN, TANGENT DISTANCE T MAY BE IGNORED

OFFSET Y, mm

L, m	W, mm	X, m													
		3.0 (10')	4.5 (15')	6.0 (20')	7.5 (25')	9.0 (30')	12.0 (40')	13.5 (45')	15.0 (50')	18.0 (60')	21.0 (70')	22.5 (75')	24.0 (80')	27.0 (90')	30.0 (100')
W/L = 1:5															
7.5 (25')	1500 (5')	240 (0.80')	540 (1.80')	960 (3.20')	1500 (5.00')										
15.0 (50')	3000 (10')	120 (0.40')	270 (0.90')	480 (1.60')	750 (2.50')	1080 (3.60')	1920 (6.40')	2430 (8.10')	3000 (10.00')						
W/L = 1:10															
15.0 (50')	1500 (5')	60 (0.20')	135 (0.45')	240 (0.80')	375 (1.25')	540 (1.80')	960 (3.20')	1215 (4.05')	1500 (5.00')						
30.0 (100')	3000 (10')	30 (0.10')	68 (0.23')	120 (0.40')	188 (0.63')	270 (0.90')	480 (1.60')	608 (2.03')	750 (2.50')	1080 (3.60')	1470 (4.90')	1688 (5.63')	1920 (6.40')	2430 (8.10')	3000 (10.00')
W/L = 1:15															
13.5 (45')	900 (3')	44 (0.15')	100 (0.33')	178 (0.59')	278 (0.93')	400 (1.33')	711 (2.37')	900 (3.00')							
22.5 (75')	1500 (5')	27 (0.09')	60 (0.20')	107 (0.36')	167 (0.56')	240 (0.80')	427 (1.42')	540 (1.80')	667 (2.22')	960 (3.20')	1307 (4.36')	1500 (5.00')			
27.0 (90')	1800 (6')	22 (0.07')	50 (0.17')	89 (0.30')	139 (0.46')	200 (0.67')	356 (1.19')	450 (1.50')	555 (1.85')	800 (2.67')	1089 (3.63')	1250 (4.17')	1422 (4.74')	1800 (6.00')	

DIMENSIONS SHOWN ON THIS PLAN FOR METRIC AND ENGLISH UNITS ARE NOT EXACTLY EQUAL VALUES. IF METRIC UNITS ARE USED, ALL VALUES USED FOR CONSTRUCTION SHALL BE METRIC VALUES. IF ENGLISH UNITS ARE USED, ALL VALUES USED FOR CONSTRUCTION SHALL BE ENGLISH VALUES.

AMERICAN PUBLIC WORKS ASSOCIATION - SOUTHERN CALIFORNIA CHAPTER		
PROMULGATED BY THE PUBLIC WORKS STANDARDS INC. GREENBOOK COMMITTEE 1984 REV. 1996	<h2 style="margin: 0;">MEDIAN FLARE</h2> <p style="margin: 0; font-weight: bold;">USE WITH STANDARD SPECIFICATIONS FOR PUBLIC WORKS CONSTRUCTION</p>	STANDARD PLAN METRIC <h1 style="margin: 0;">141 - 1</h1> SHEET 1 OF 1

SEE RDMD STANDARD PLAN 141-1-OC FOR CONDITIONS

The following Standard Plans for Public Works Construction, 1997 Edition, of the American Public Works Association (Southern California Chapter) and Associated General Contractors of California (Southern California Districts) have been adopted by the Orange County Resources & Development Management Department (RDMD) with conditions which shall apply to RDMD use. The conditions are listed below.

APWA # RDMD # Name and Conditions
 141-1 141-1-0C Median Flare

1. 60' (18.00m) flare for a 14' (4.20m) median width, use R=4' (1.20m)
 100' (30.00m) flare for a 24' (7.20m) median width, use R=7' (2.10m)
 For W/L = 1:10

DIST. X (m)	10' (3.00)	15' (4.50)	20' (6.00)	25' (7.50)	30' (9.00)	40' (12.00)	45' (13.50)	50' (15.00)	60' (18.00)
OFFSET Y (mm)	0.17' (50)	0.38' (112)	0.67' (200)	1.04' (312)	1.50' (450)	2.67' (800)	3.38' (1012)	4.17' (1250)	6.00' (1800)

ORANGE COUNTY RESOURCES & DEVELOPMENT MANAGEMENT DEPARTMENT

Approved

H. I. Nakasone
 H. I. Nakasone, Chief Engineer

Adopted: Res. 91-1481

Revised: Res. 96-546; 06-010

STD. PLAN

141-1-0C

APWA STANDARD PLAN - MEDIAN FLARE

SHT. 1 OF 1

DRILL AND TAP HOLE AND INSTALL
20 mm x 32 mm (3/4" x 1 1/4")
STAINLESS STEEL SOCKET SET
SCREW WITH 10 mm (3/8")
RECESSED HEX HOLE ALL
THREADS TO BE NC.

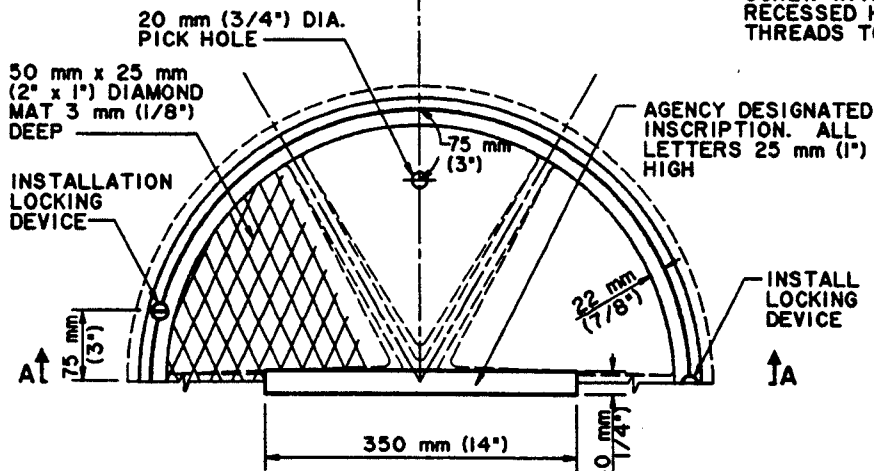

PLAN

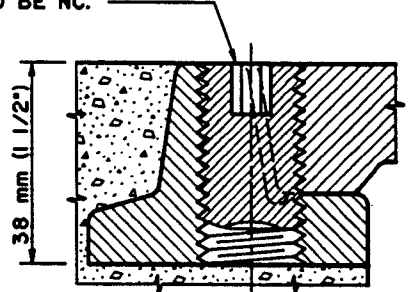

LOCKING DEVICE

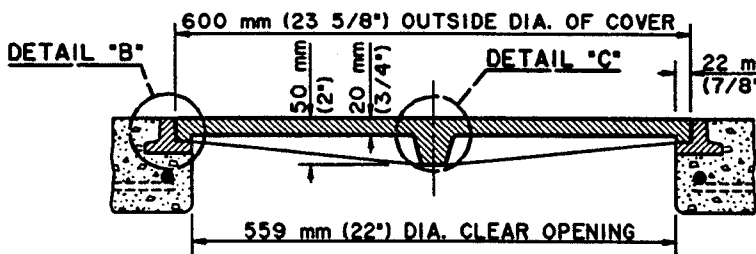

SECTION A-A

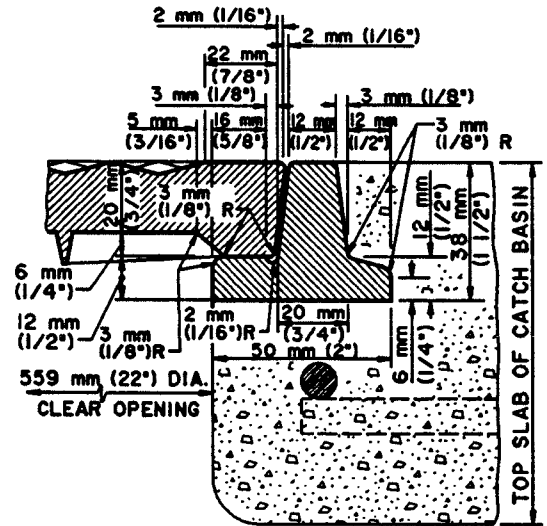

DETAIL "B"

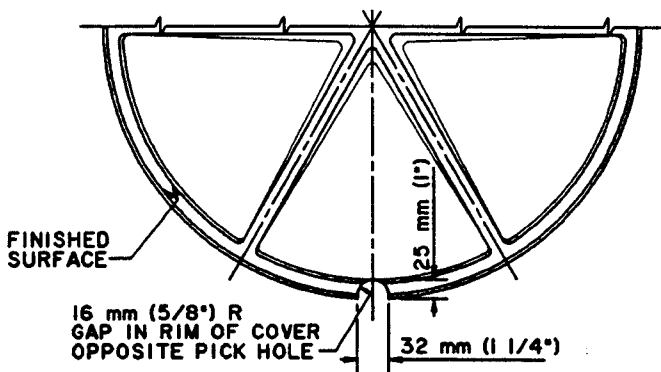

BOTTOM OF MANHOLE COVER

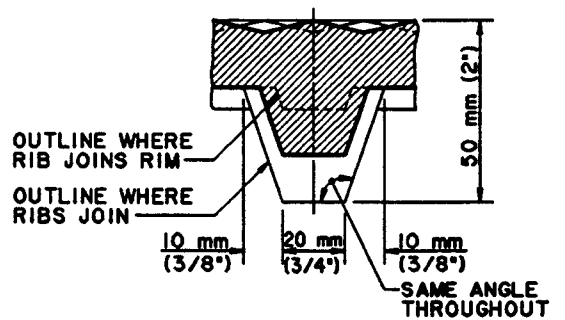

DETAIL "C"

AMERICAN PUBLIC WORKS ASSOCIATION - SOUTHERN CALIFORNIA CHAPTER

PROMULGATED BY THE
PUBLIC WORKS STANDARDS INC.,
GREENBOOK COMMITTEE
1984
REV. 1996

**CATCH BASIN
MANHOLE FRAME AND COVER**

USE WITH STANDARD SPECIFICATIONS FOR PUBLIC WORKS CONSTRUCTION

STANDARD PLAN
METRIC

312 - 2

SHEET 1 OF 2

SEE RDMD STANDARD PLAN 312-2-OC FOR CONDITIONS

NOTES

1. THE CAST IRON USED SHALL CONFORM WITH ASTM A-48M CLASS 35B.
2. THE FRAME AND COVER SHALL BE COATED WITH ASPHALTUM OR BITUMINOUS PAINT AFTER TESTING AND INSPECTION.
3. FOUNDRY IDENTIFYING MARK, HEAT AND DATE SHALL BE CAST ON THE BOTTOM OF THE COVER AND ON THE INSIDE OF THE FRAME.
4. IMPORTED COVERS AND FRAMES SHALL HAVE THE COUNTRY OF ORIGIN MARKING IN COMPLIANCE WITH FEDERAL REGULATIONS.
5. WEIGHT OF FRAME SHALL BE 15 Kg (30 POUNDS). WEIGHT OF COVER SHALL BE 40 kg (85 POUNDS). ACTUAL WEIGHTS SHALL BE WITHIN A RANGE OF 95% TO 110%.
6. THE MANHOLE FRAME AND COVER SHALL BE INSPECTED BY THE ENGINEER PRIOR TO SHIPMENT TO THE JOB SITE. ACCEPTANCE WILL BE INDICATED BY THE AGENCY'S MARK.
7. THE PROOF-LOAD FOR TEST METHOD B OF THE STANDARD SPECIFICATIONS IS 13,000 kg (28,600 POUNDS).
8. DIMENSIONS SHOWN ON THIS PLAN FOR METRIC AND ENGLISH UNITS ARE NOT EXACT EQUAL VALUES. IF METRIC VALUES ARE USED, ALL VALUES USED FOR CONSTRUCTION SHALL BE METRIC VALUES. IF ENGLISH UNITS ARE USED, ALL VALUES USED FOR CONSTRUCTION SHALL BE ENGLISH UNITS.

AMERICAN PUBLIC WORKS ASSOCIATION - SOUTHERN CALIFORNIA CHAPTER

CATCH BASIN MANHOLE FRAME AND COVER

STANDARD PLAN
METRIC
312 - 1
SHEET 2 OF 2

SEE RDMD STANDARD PLAN 312-2-OC FOR CONDITIONS

The following Standard Plans for Public Works Construction, 1997 Edition of the American Public Works Association (Southern California Chapter) and Associated General Contractors of California (Southern California Districts) have been adopted by the Orange County Resources & Development Management Department (RDMD) with conditions which shall apply to RDMD use. The conditions are listed below.

<u>APWA #</u>	<u>RDMD #</u>	<u>Name and Conditions</u>
312-2	312-2-0C	<u>Catch Basin ManHole Frame and Cover</u> 1. Delete Note # 2 2. Frame and cover shall be galvanized.

ORANGE COUNTY RESOURCES & DEVELOPMENT MANAGEMENT DEPARTMENT

Approved

H. I. Nakasone, Chief Engineer

Adopted: Res. 91-1481 Revised: Res. 06-010

STD. PLAN

312-2-0C

APWA STANDARD PLAN-CATCH BASIN MANHOLE FRAME AND COVER

SHT. 1 OF 1

BACKFLOW PREVENTER ASSEMBLY:

DOUBLE CHECK -----



REDUCED PRESSURE -----



CONTROLLER -----



DRINKING FOUNTAIN -----



ELECTRICAL CONDUIT -----

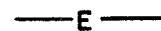

PIPE:

PRESSURE MAIN LINE -----



LATERAL LINE -----



POINT OF CONNECTION -----

P O C

POWER SOURCE -----

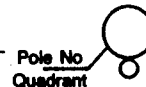

PULL BOX:

HIGH VOLTAGE -----



LOW VOLTAGE -----



PUMP -----



SLEEVE:

NEW -----

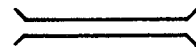

EXISTING -----

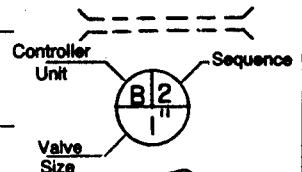

STATION DESIGNATION (REMOTE CONTROL VALVE) -----

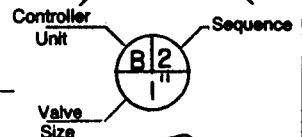

THRUST BLOCK -----



AMERICAN PUBLIC WORKS ASSOCIATION - SOUTHERN CALIFORNIA CHAPTER

PROMULGATED BY THE
PUBLIC WORKS STANDARDS INC.,
GREENBOOK COMMITTEE
1984

LANDSCAPE IRRIGATION SYMBOLS

STANDARD PLAN

500 - 0

USE WITH STANDARD SPECIFICATIONS FOR PUBLIC WORKS CONSTRUCTION

SHEET 1 OF 2

VACUUM BREAKER ASSEMBLY:

ATMOSPHERIC -----



PRESSURE -----



VALVE ASSEMBLY -----

ANGLE -----



CHECK -----



GATE -----



HOSE BIB -----



QUICK COUPLER (BELOW GRADE) -----



QUICK COUPLER (ABOVE GRADE) -----



PRESSURE REGULATOR -----



PRESSURE RELIEF -----



REMOTE CONTROL -----



WATER METER -----



Y-STRAINER -----



SWING JOINT ASSEMBLY - ABOVE GRADE:

SINGLE -----



DOUBLE -----



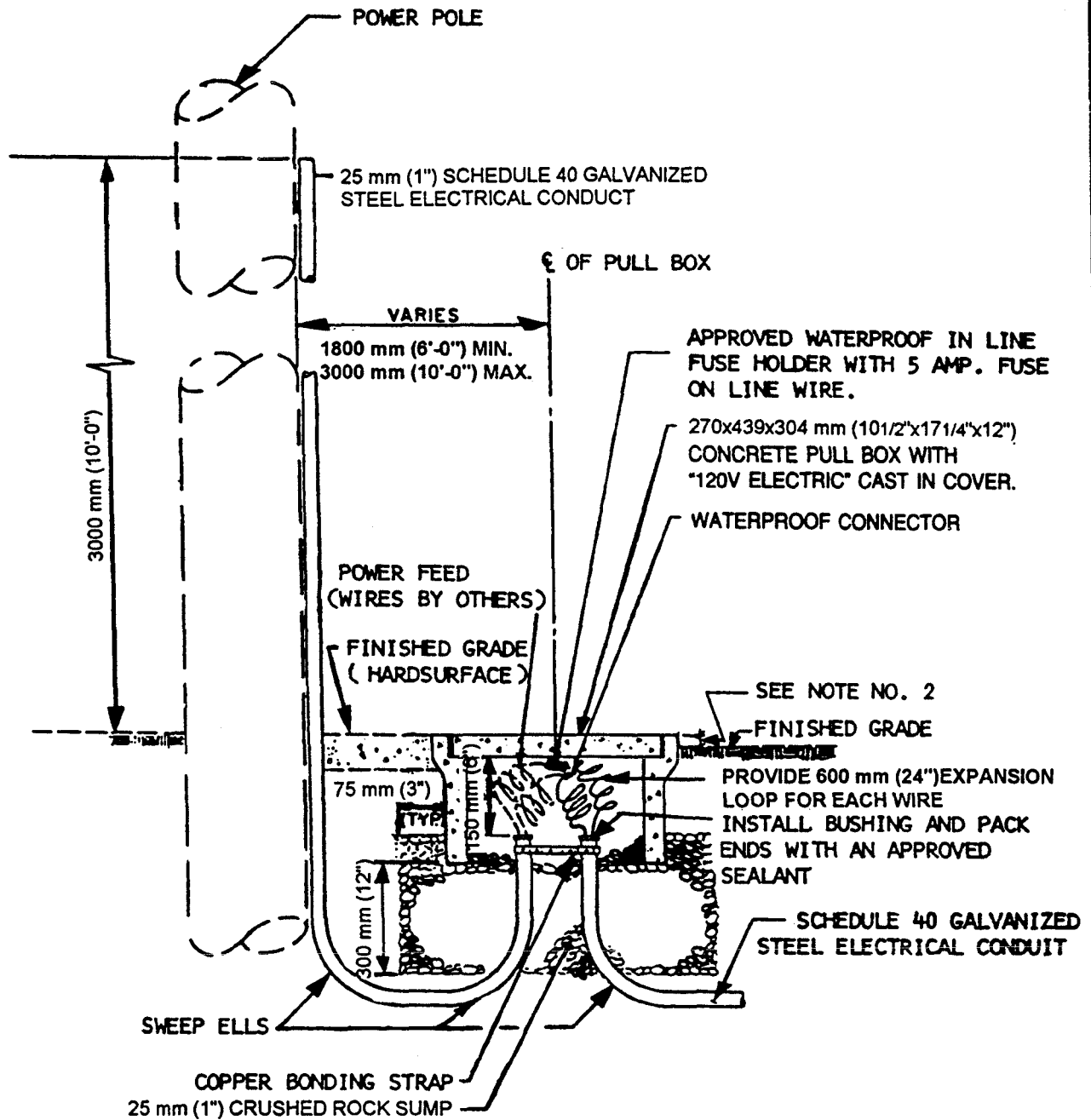

NOTES:

1. AREA AROUND BOX CAN EITHER BE PLANTED, HARDSURFACE OR A COMBINATION.
2. TOP OF BOX:
 12 mm (1/2") ABOVE GRADE FOR LAWN
 25 mm (1") ABOVE GRADE FOR GROUND COVER OR SHRUBS
3. CRUSHED ROCK SHALL COVER ELECTRICAL BOX PIPE OPENINGS TO PREVENT SOIL ENTRY.
4. THE CONTRACTOR SHALL SUBMIT TO THE ENGINEER FOR APPROVAL, PRIOR TO PURCHASE, THE TYPE OF WATERPROOF CONNECTION THAT WILL BE USED.

SYMBOL ON PLAN

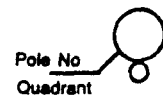

CASE 1

AMERICAN PUBLIC WORKS ASSOCIATION - SOUTHERN CALIFORNIA CHAPTER		
PROMULGATED BY THE PUBLIC WORKS STANDARDS INC., GREENBOOK COMMITTEE 1984 REV. 1996	<h2 style="margin: 0;">ELECTRICAL SERVICE</h2>	STANDARD PLAN METRIC <h1 style="margin: 0;">501 - 1</h1>
USE WITH STANDARD SPECIFICATIONS FOR PUBLIC WORKS CONSTRUCTION		SHEET 1 OF 3

SEE RDMD STANDARD PLAN 501-1-OC FOR CONDITIONS

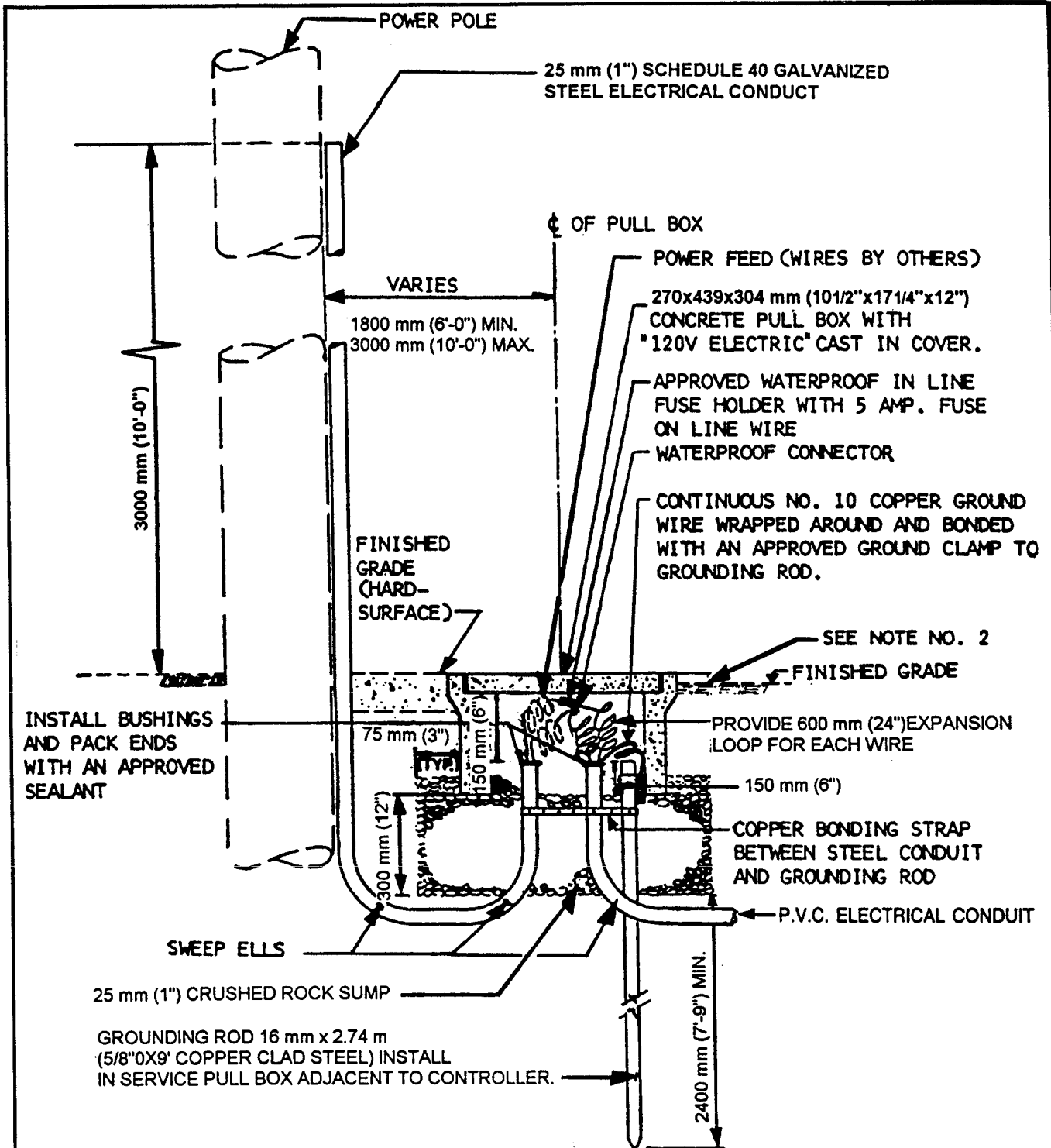

NOTES:

1. AREA AROUND BOX CAN EITHER BE PLANTED, HARDSURFACE OR A COMBINATION.
2. TOP OF BOX:
 - 12 mm (1/2") ABOVE GRADE FOR LAWN
 - 25 mm (1") ABOVE GRADE FOR GROUND COVER OR SHRUBS
3. CRUSHED ROCK SHALL COVER ELECTRICAL BOX PIPE OPENINGS TO PREVENT SOIL ENTRY.
4. THE CONTRACTOR SHALL SUBMIT TO THE ENGINEER FOR APPROVAL, PRIOR TO PURCHASE, THE TYPE OF WATERPROOF CONNECTION THAT WILL BE USED

CASE 2

SYMBOL ON PLAN

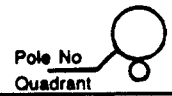

AMERICAN PUBLIC WORKS ASSOCIATION - SOUTHERN CALIFORNIA CHAPTER		STANDARD PLAN METRIC
ELECTRICAL SERVICE		501 - 1
		SHEET 2 OF 3

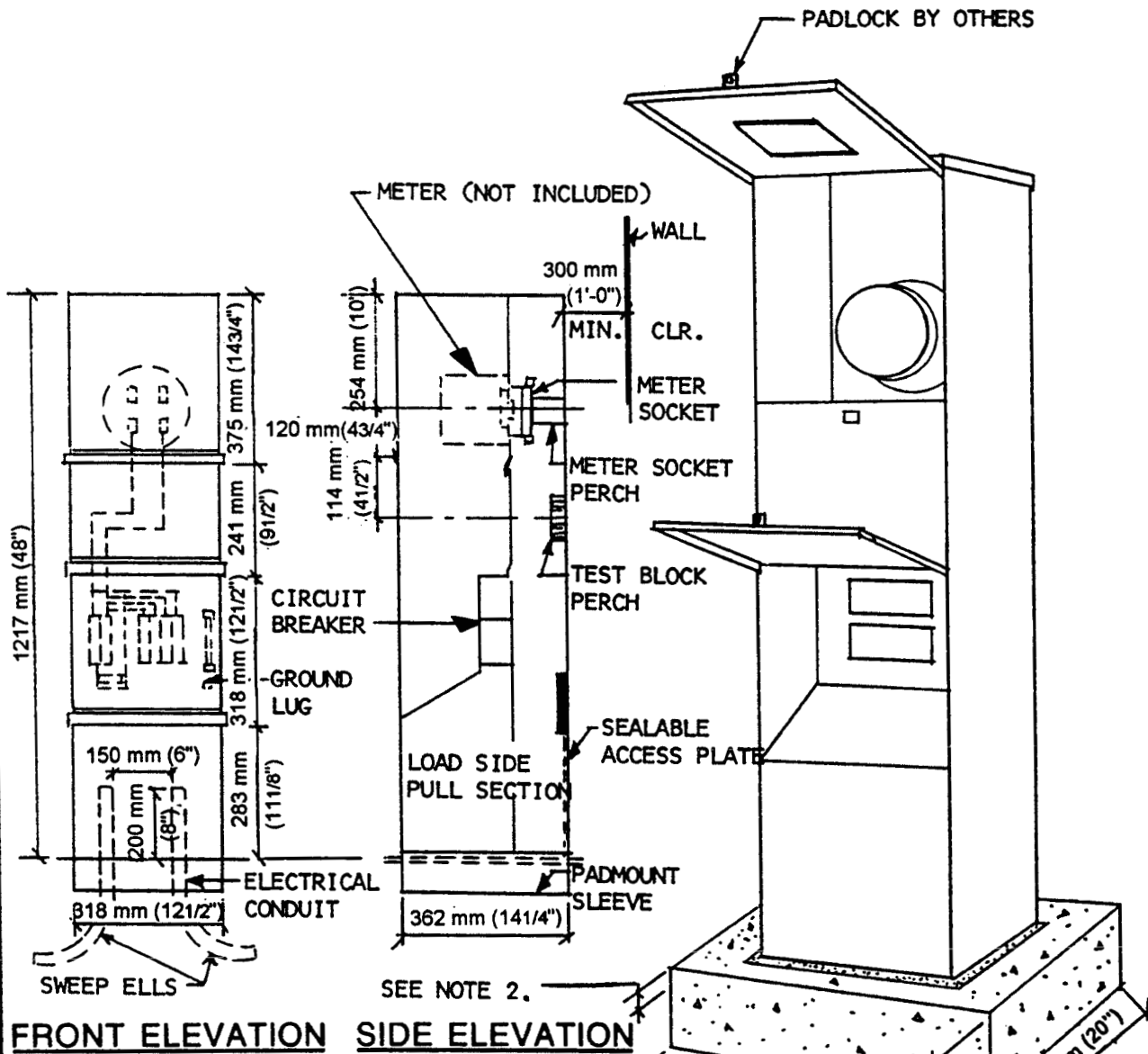

NOTES:

1. AREA AROUND BOX CAN EITHER BE PLANTED, HARDSURFACE OR A COMBINATION.
2. TOP OF CONCRETE BASE:
 12 mm (1/2") ABOVE GRADE FOR LAWN
 25 mm (1") ABOVE GRADE FOR GROUND COVER OR SHRUBS
3. CONCRETE BASE SHALL BE 265-C-14 (450-C-2000) CONCRETE.
4. FILL PADMOUNT WITH 25 mm (1") CRUSHED ROCK 300 mm (12") DEEP.
5. MATERIAL:
 BODY-12 GAUGE GALVANIZED DEADFRONT AND COVERS 16 GAUGE GALVANIZED.
 FINISHED-IRON PHOSPHATE DIP, ZINC CHROMATE PRIME, GREEN BAKED ENAMEL
 2 POLE MAIN (100 AMP) CIRCUIT BREAKER INCLUDED.

CASE 3

AMERICAN PUBLIC WORKS ASSOCIATION - SOUTHERN CALIFORNIA CHAPTER	STANDARD PLAN METRIC
ELECTRICAL SERVICE	501 - 1
	SHEET 3 OF 3

The following Standard Plans for Public Works Construction, 1997 Edition, of the American Public Works Association (Southern California Chapter) and Associated General Contractors of California (Southern California Districts) have been adopted by the Orange County Resources & Development Management Department (RDMD) with conditions which shall apply to RDMD use. The conditions are listed below.

<u>APWA #</u>	<u>RDMD #</u>	<u>Name and Conditions</u>
501-1	501-1-0C	<u>Electrical Service - Sheet 1</u> 1. Delete schedule 40 galvanized steel at power pole Add schedule 80 PVC 2. Add approved to waterproof connection 3. Delete schedule 40 galvanized steel at sweep ell Add schedule 40 PVC 4. Delete copper bonding strap
501-1	501-1-0C	<u>Electrical Service - Sheet 2, Case 2</u> Not Approved
501-1	501-1-0C	<u>Electrical Service - Sheet 3, Case 3</u> 1. Add note 6. Equipment shall be UL listed 2. Add note 7. Slope concrete away from base @ 1% min. 3. Add note 8. Install ground rod $\frac{5}{8}$ " x 9' (16 mm x 2.74 m copper clad steel) in meter cabinet 4. Add note 9. Install per NEC Requirements 5. Add continuous No. 10 copper ground wire wrapped around and bonded with an approved ground clamp to grounding rod.

ORANGE COUNTY RESOURCES & DEVELOPMENT MANAGEMENT DEPARTMENT

Approved

H. I. Nakasone
 H. I. Nakasone, Chief Engineer

Adopted: Res. 06-010 Revised:

STD. PLAN

501-1-0C

APWA STANDARD PLAN - ELECTRICAL SERVICE

SHT. 1 OF 1

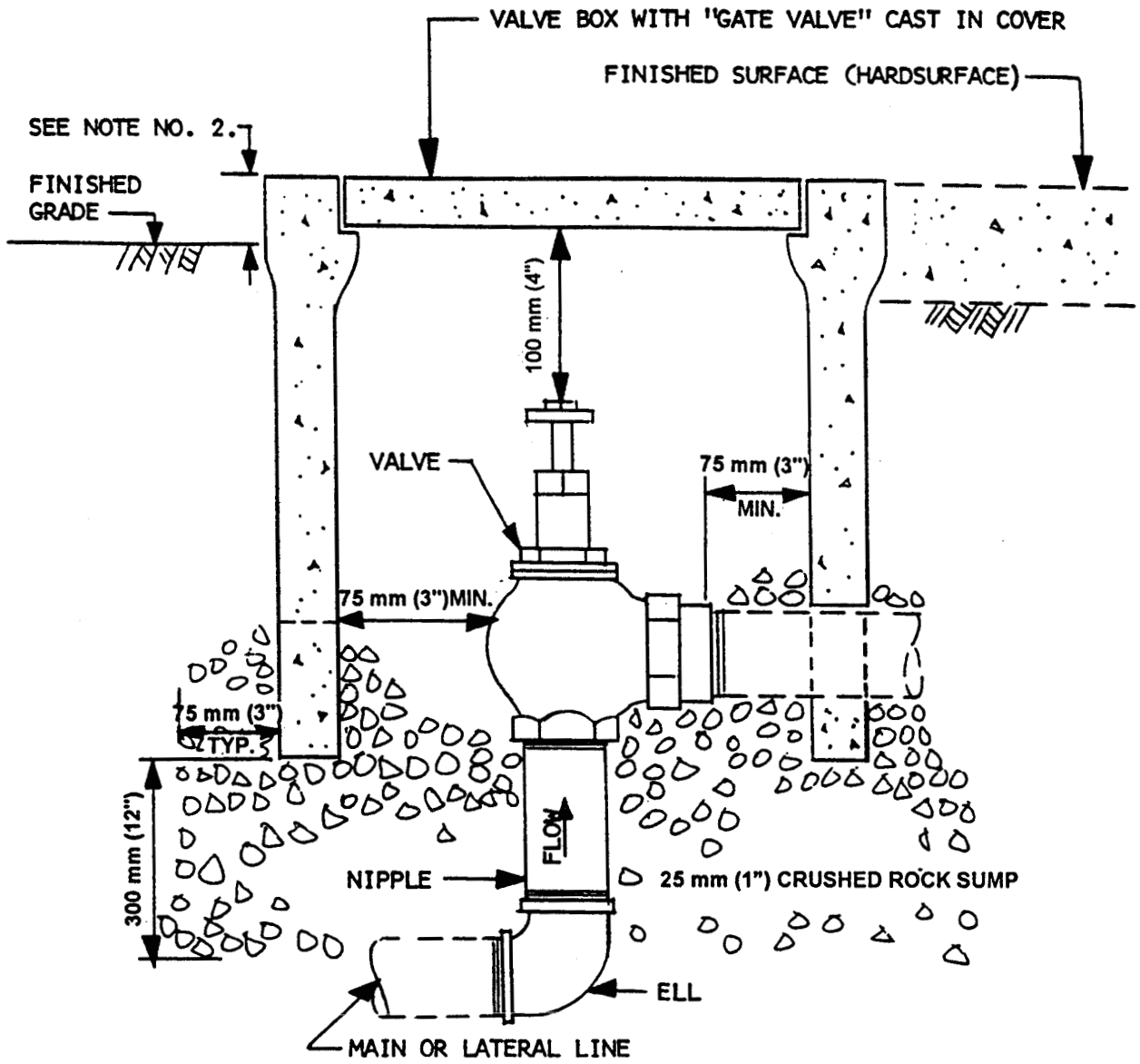

NOTES:

1. AREA AROUND BOX CAN EITHER BE PLANTED, HARDSURFACE OR A COMBINATION.
2. TOP OF BOX:
 12 mm (1/2") ABOVE GRADE FOR LAWN
 25 mm (1") ABOVE GRADE FOR GROUND COVER OR SHRUBS
3. CLOSE NIPPLES SHALL NOT BE USED.
4. CRUSHED ROCK SHALL COVER VALVE BOX PIPE OPENINGS TO PREVENT SOIL ENTRY.

SYMBOL ON PLAN



AMERICAN PUBLIC WORKS ASSOCIATION - SOUTHERN CALIFORNIA CHAPTER		
PROMULGATED BY THE PUBLIC WORKS STANDARDS INC., GREENBOOK COMMITTEE 1984 REV. 1996	<h2 style="margin: 0;">ANGLE VALVE</h2> <p style="margin: 0; font-weight: normal;">USE WITH STANDARD SPECIFICATIONS FOR PUBLIC WORKS CONSTRUCTION</p>	STANDARD PLAN METRIC <h1 style="margin: 0;">502 - 1</h1> SHEET 1 OF 1

SEE RDMD STANDARD PLAN 502-1-OC FOR CONDITIONS

The following Standard Plans for Public Works Construction, 1997 Edition, of the American Public Works Association (Southern California Chapter) and Associated General Contractors of California (Southern California Districts) have been adopted by the Orange County Resources & Development Management Department (RDMD) with conditions which shall apply to RDMD use.

The conditions are listed below.

APWA # RDMD # Name and Conditions

502-1

502-1-0C

Angle Valve

1. Use Class 315 P.V.C. pipe and Schedule 40 P.V.C. fittings for 2" (50 mm) or greater. Use Schedule 40 P.V.C. pipe and fittings for sizes 1-1/2" (40 mm) or less.
2. Provide two operating keys for valves.
3. For Turf Areas - All angle valves shall be located outside the designated playing field (i.e., ball diamond, soccer, etc.).
4. Valves up to 2" (50 mm) diameter shall have malleable iron "Tee" handles. Valves larger than 2" (50 mm) shall have square operating nuts.
5. Valve box shall be one of the following cases as specified on the plans:
 - Case 1. Concrete box w/concrete cover
 - Case 2. Concrete box w/locking cast iron cover
 - Case 3. Plastic box w/locking plastic cover

ORANGE COUNTY RESOURCES & DEVELOPMENT MANAGEMENT DEPARTMENT

Approved



H.I. Nakasone, Chief Engineer

Adopted: Res. 86-1141 Revised: Res. 88-1341; 91-1481; 06-010

STD. PLAN

502-1-0C

APWA STANDARD PLAN - ANGLE VALVE

SHT. 1 OF 1

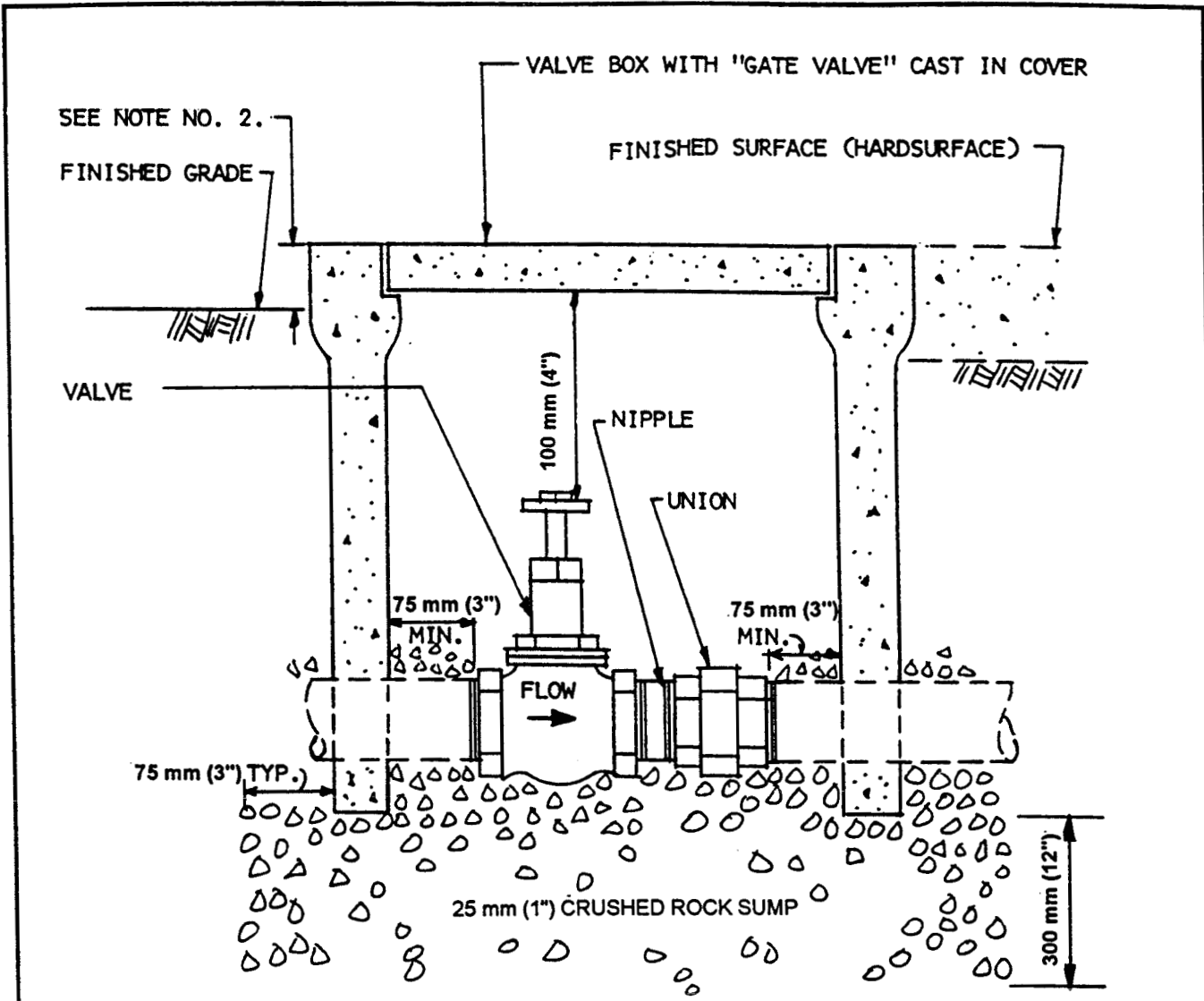

NOTES:

1. AREA AROUND BOX CAN EITHER BE PLANTED, HARDSURFACE OR A COMBINATION.
2. TOP OF BOX:
 12 mm (1/2") ABOVE GRADE FOR LAWN
 25 mm (1") ABOVE GRADE FOR GROUND COVER OR SHRUBS
3. CLOSE NIPPLES SHALL NOT BE USED.
4. CRUSHED ROCK SHALL COVER VALVE BOX PIPE OPENINGS TO PREVENT SOIL ENTRY.

SYMBOL ON PLAN



AMERICAN PUBLIC WORKS ASSOCIATION - SOUTHERN CALIFORNIA CHAPTER		
PROMULGATED BY THE PUBLIC WORKS STANDARDS INC., GREENBOOK COMMITTEE 1984 REV. 1996	<h2 style="margin: 0;">GATE VALVE</h2> <p style="margin: 0;">USE WITH STANDARD SPECIFICATIONS FOR PUBLIC WORKS CONSTRUCTION</p>	STANDARD PLAN METRIC <h3 style="margin: 0;">503 - 1</h3> SHEET 1 OF 1

SEE RDMD STANDARD PLAN 503-1-OC FOR CONDITIONS

The following Standard Plans for Public Works Construction, 1997 Edition, of the American Public Works Association (Southern California Chapter) and Associated General Contractors of California (Southern California Districts) have been adopted by the Orange County Resources & Development Management Department (RDMD) with conditions which apply to RDMD use. The conditions are listed below.

<u>APWA #</u>	<u>RDMD #</u>	<u>Name and Conditions</u>
503-1	503-1-0C	<u>Gate Valve</u>

1. Delete 4" (100 mm) dimension from base of cover to top of valve operating wheel.
2. All gate valves shall be enclosed in a valve enclosure with hinged, vandal proof locking cover. Provide cast-iron or precast concrete enclosure.
3. Valves up to 2" (50 mm) diameter shall have malleable iron "Tee" handles. Valves larger than 2" (50 mm) shall have square operating nuts.
4. Provide two operating keys to valves buried 18" (450mm) or deeper.
5. Add enclosure extensions as required.
6. All gate valves and enclosures shall be located outside the designated playing field (i.e., ball diamond, soccer, etc.)

ORANGE COUNTY RESOURCES & DEVELOPMENT MANAGEMENT DEPARTMENT

Approved

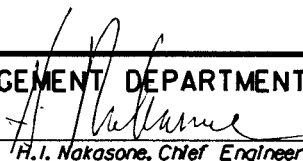
H.I. Nakasone, Chief Engineer

Adopted: Res. 86-1141 Revised: Res. 88-1341; 91-1481; 06-010

STD. PLAN

503-1-0C

APWA STANDARD PLAN - GATE VALVE

SHT. 1 OF 1

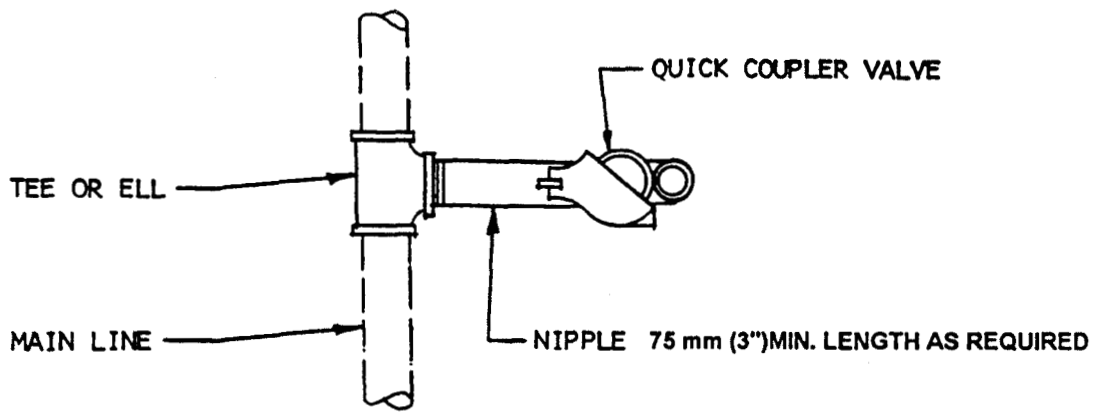

PLAN

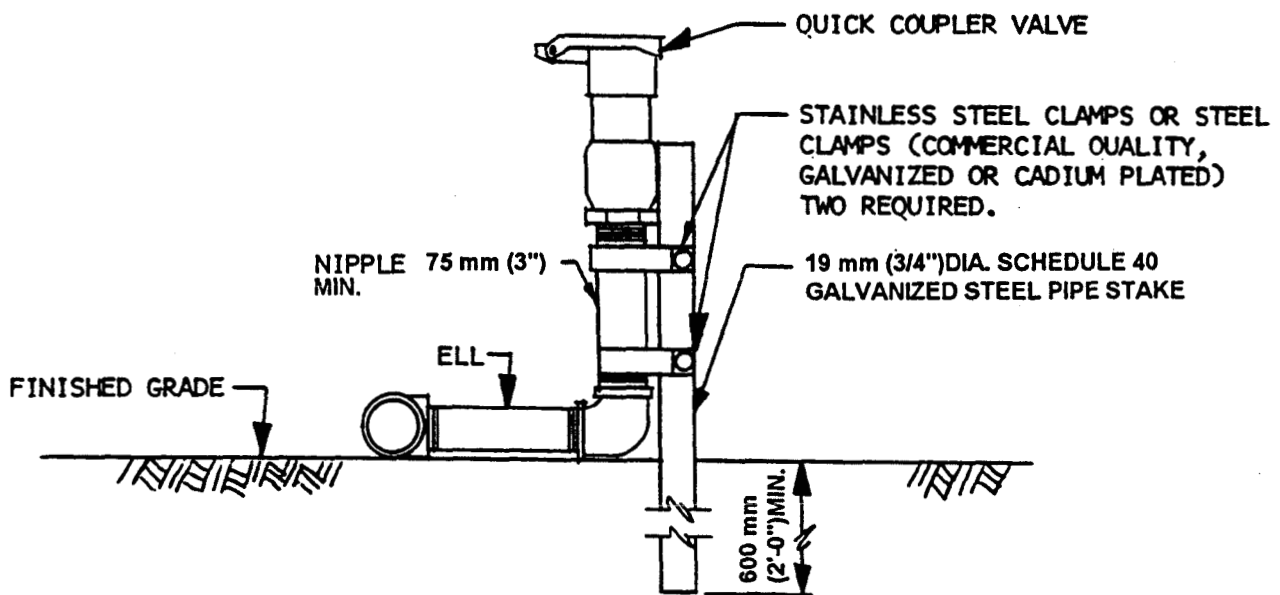

ELEVATION

NOTES:

1. ALL PIPE AND FITTINGS SHALL BE SCHEDULE 40 GALVANIZED STEEL UNLESS OTHERWISE SPECIFIED.
2. QUICK COUPLER VALVE SHALL BE SET 250 mm (10") ABOVE FINISHED GRADE.
3. PIPE SIZE FROM MAIN LINE SHALL MATCH QUICK COUPLER INLET DIAMETER.
4. DISSIMILAR METALS SHALL BE SEPARATED BY AN APPROVED DIELECTRIC COUPLING.
5. PLASTIC PIPE SHALL NOT BE USED ABOVE FINISHED GRADE.

SYMBOL ON PLAN

ABOVE GRADE PIPING INSTALLATION



AMERICAN PUBLIC WORKS ASSOCIATION - SOUTHERN CALIFORNIA CHAPTER		
<small>PROMULGATED BY THE PUBLIC WORKS STANDARDS INC., GREENBOOK COMMITTEE 1984 REV. 1996</small>	<h2 style="margin: 0;">QUICK COUPLER VALVE</h2> <p style="margin: 0;">USE WITH STANDARD SPECIFICATIONS FOR PUBLIC WORKS CONSTRUCTION</p>	<small>STANDARD PLAN METRIC</small> <h2 style="margin: 0;">504 - 1</h2> <small>SHEET 1 OF 2</small>

SEE RDMD STANDARD PLAN 504-1-OC FOR CONDITIONS

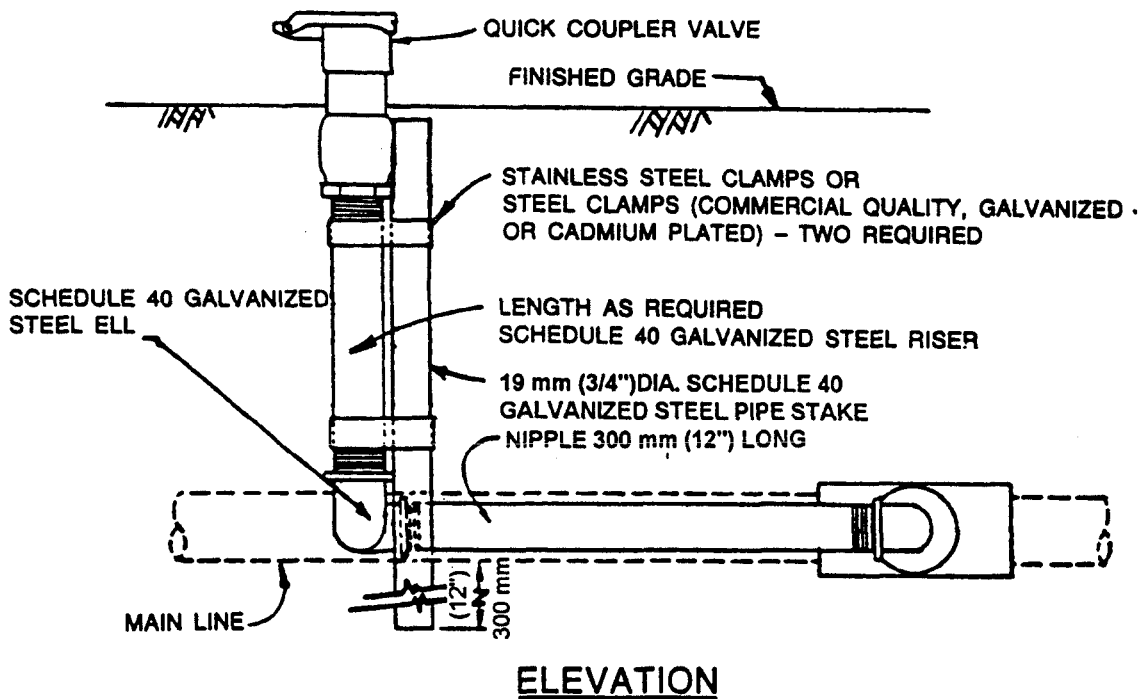
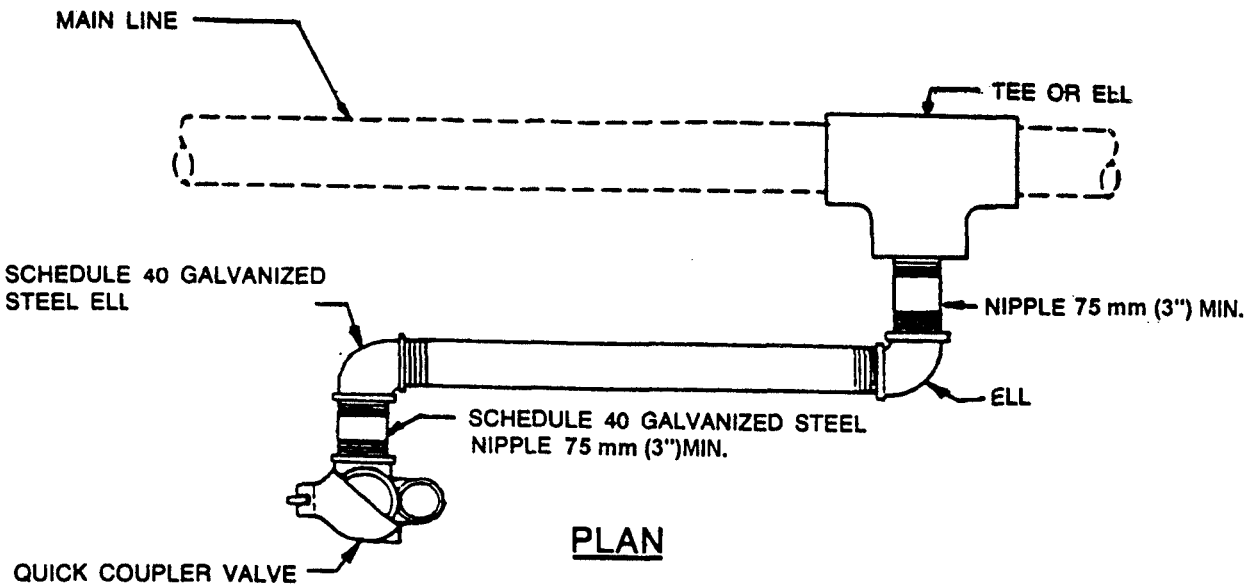

NOTES:

1. ALL PIPE AND FITTINGS SHALL BE SCHEDULE 80 PVC UNLESS OTHERWISE SPECIFIED.
2. QUICK COUPLER VALVE IN LAWN AREAS SHALL BE SET AT GRADE.
3. QUICK COUPLER VALVE IN SHRUB AREAS SHALL BE SET 100 mm (4") ABOVE FINISHED GRADE.
4. PIPE SIZE FROM MAIN LINE SHALL MATCH QUICK COUPLER INLET DIAMETER.
5. DISSIMILAR METALS SHALL BE SEPARATED BY AN APPROVED DIELECTRIC COUPLING.
6. PLASTIC PIPE SHALL NOT BE USED ABOVE FINISHED GRADE.

BELOW GRADE PIPING INSTALLATION

SYMBOL ON PLAN



AMERICAN PUBLIC WORKS ASSOCIATION - SOUTHERN CALIFORNIA CHAPTER

STANDARD PLAN
METRIC

QUICK COUPLER VALVE

504 - 1
SHEET 2 OF 2

The following Standard Plans for Public Works Construction, 1997 Edition, of the American Public Works Association (Southern California Chapter) and Associated General Contractors of California (Southern California Districts) have been adopted by the Orange County Resources & Development Management Department (RDMD) with the conditions which shall apply to RDMD use. The conditions are listed below.

<u>APWA #</u>	<u>RDMD #</u>	<u>Name and Conditions</u>
504-1	504-1-0C	<u>Quick Coupler Valve-Sheet 1 of 2</u> <ol style="list-style-type: none"> Quick coupler valve shall be brass and have locking cover. <u>For Turf Areas</u> - All quick coupler valves shall be located outside the designated playing area (i.e., ball diamond, soccer field, etc.). Revise Note 5 to read: Schedule 80 PVC risers, fittings and Schedule 40 ultraviolet resistant PVC pipe are approved for above ground installation.

504-1	504-1-0C	<u>Quick Coupler Valve-Sheet 2 of 2</u> <ol style="list-style-type: none"> Quick coupler valve shall be brass and have vinyl top and locking cover. <u>For Turf Areas</u> - All quick coupler valves shall be located outside the designated playing area (i.e., ball diamond, soccer field, etc.). Revise Note 6 to read: Schedule 80 PVC risers, fittings and Schedule 40 ultraviolet resistant PVC pipe are approved for above ground installation.
-------	----------	---

ORANGE COUNTY RESOURCES & DEVELOPMENT MANAGEMENT DEPARTMENT

Approved

H. I. Nakasone
H. I. Nakasone, Chief Engineer

Adopted: Res.

Revised: Res. 88-1341; 91-1481; 06-010

STD. PLAN

504-1-0C

APWA STANDARD PLAN - QUICK COUPLER VALVE

SHT. 1 OF 1

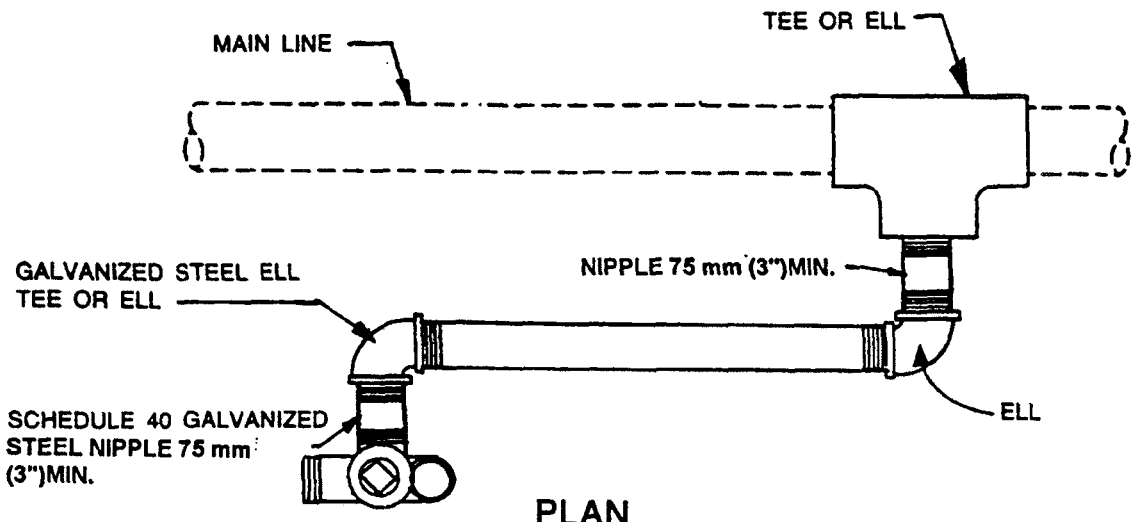

PLAN

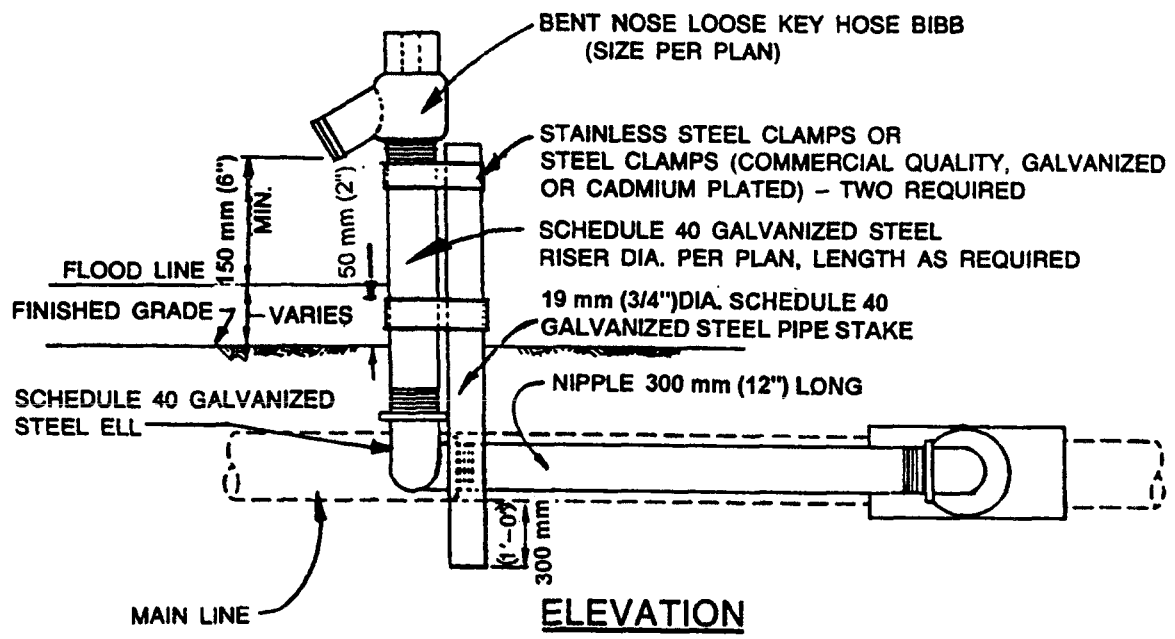

ELEVATION

- NOTES:**
1. ALL PIPE AND FITTINGS SHALL BE SCHEDULE 80 PVC UNLESS OTHERWISE SPECIFIED.
 2. PIPE SIZE FROM MAIN LINE LINE SHALL MATCH HOSE BIBB INLET DIAMETER.
 3. DISSIMILAR METALS SHALL BE SEPARATED BY AN APPROVED DIELECTRIC COUPLING.
 4. PLASTIC PIPE SHALL NOT BE USED ABOVE FINISHED GRADE.

SYMBOL ON PLAN



BELOW GRADE PIPING INSTALLATION

AMERICAN PUBLIC WORKS ASSOCIATION - SOUTHERN CALIFORNIA CHAPTER		
PROMULGATED BY THE PUBLIC WORKS STANDARDS INC., GREENBOOK COMMITTEE 1984 REV. 1996	<h2 style="margin: 0;">HOSE BIBB VALVE</h2>	STANDARD PLAN METRIC 505 - 1 SHEET 1 OF 2
USE WITH STANDARD SPECIFICATIONS FOR PUBLIC WORKS CONSTRUCTION		

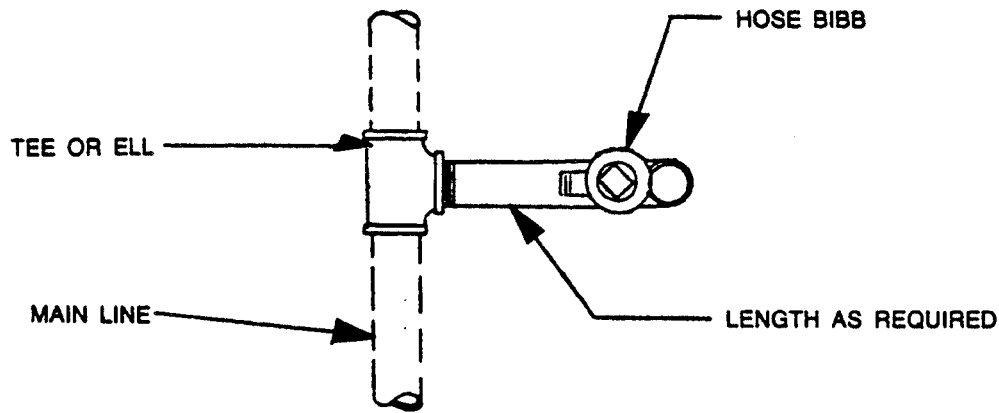

PLAN

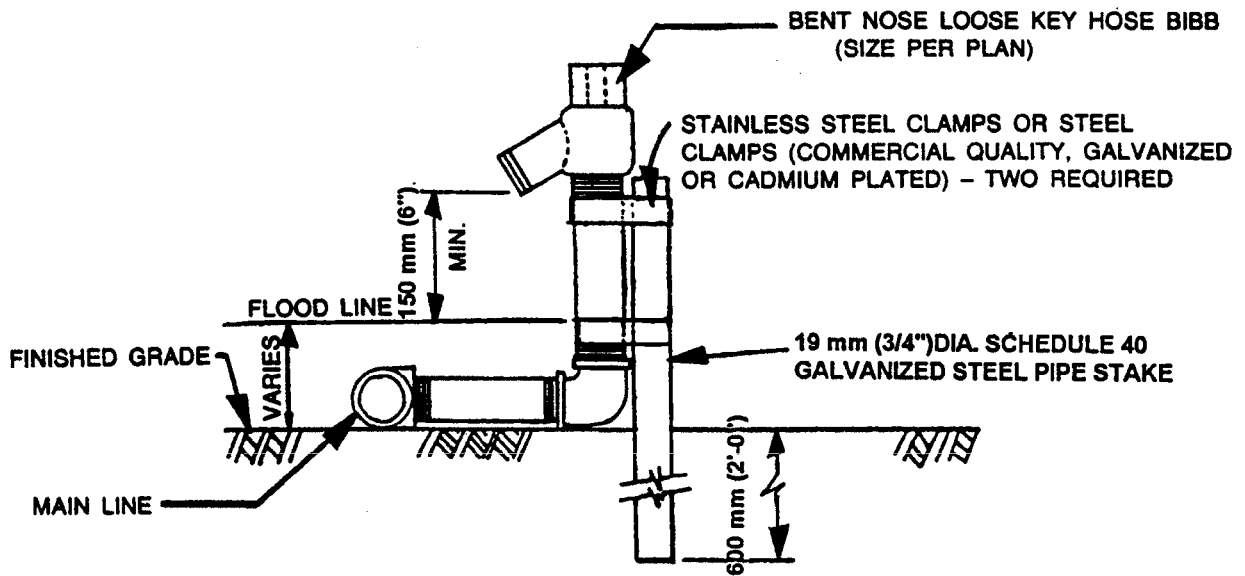

ELEVATION

NOTES:

1. ALL PIPE AND FITTINGS SHALL BE SCHEDULE 40 GALVANIZED STEEL UNLESS OTHERWISE SPECIFIED.
2. PIPE SIZE FROM MAIN LINE LINE SHALL MATCH HOSE BIBB INLET DIAMETER.
3. PLASTIC PIPE SHALL NOT BE USED ABOVE FINISHED GRADE.

ABOVE GRADE PIPING INSTALLATION

SYMBOL ON PLAN



AMERICAN PUBLIC WORKS ASSOCIATION - SOUTHERN CALIFORNIA CHAPTER

STANDARD PLAN
METRIC

HOSE BIBB VALVE

505 - 1
SHEET 2 OF 2

The following Standard Plans for Public Works Construction, 1997 Edition, of the American Public Works Association (Southern California Chapter) and Associated General Contractors of California (Southern California Districts) have been adopted by the Orange County Resources & Development Management Department (RDMD) with the conditions which shall apply to RDMD use. The conditions are listed below.

<u>APWA #</u>	<u>RDMD #</u>	<u>Name and Conditions</u>
505-1	505-1-0C	<u>Hose Bibb Valve-Sheet 1 of 2</u>

1. Hose bibb valve shall be brass.
2. For Turf Areas - All hose bibb valves shall be located outside the designated playing area (i.e., ball diamond, soccer field, etc.).
3. Revise Note 4 to read: Schedule 80 PVC risers, fittings and Schedule 40 ultraviolet resistant PVC pipe are approved for above ground installation.

505-1	505-1-0C	<u>Hose Bibb Valve-Sheet 2 of 2</u>
-------	----------	-------------------------------------

1. Hose bibb valve shall be brass.
2. For Turf Areas - All hose bibb valves shall be located outside the designated playing area (i.e., ball diamond, soccer field, etc.).
3. Revise Note 3 to read: Schedule 80 PVC risers, fittings and Schedule 40 ultraviolet resistant PVC pipe are approved for above ground installation.

ORANGE COUNTY RESOURCES & DEVELOPMENT MANAGEMENT DEPARTMENT

Approved

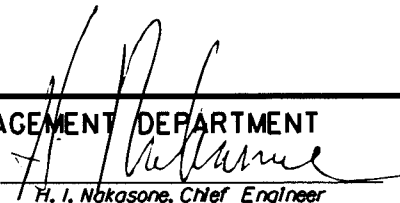

H. I. Nakasone, Chief Engineer

Adopted: Res.

Revised: 88-134I; 91-148I; 06-010

STD. PLAN

505-1-0C

APWA STANDARD PLAN - HOSE BIBB VALVE

SHT. 1 OF 1

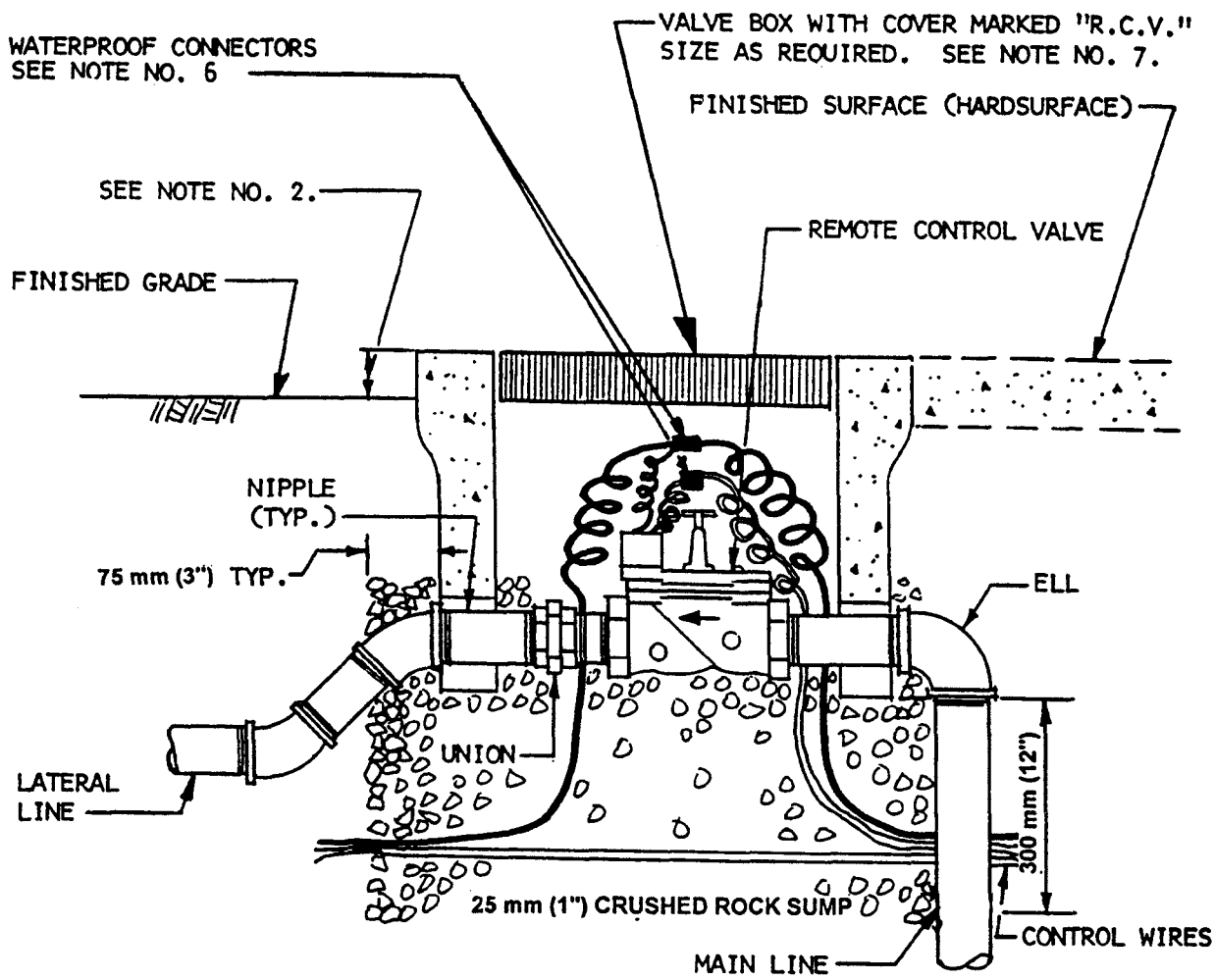

NOTES:

1. AREA AROUND BOX CAN EITHER BE PLANTED, HARDSURFACE OR A COMBINATION.
2. TOP OF BOX:
 12 mm (1/2") ABOVE GRADE FOR LAWN
 25 mm (1") ABOVE GRADE FOR GROUND COVER OR SHRUBS
3. CLOSE NIPPLES SHALL NOT BE USED.
4. PROVIDE TWO FOOT EXPANSION LOOP AT EACH WIRE CONNECTION IN VALVE BOX AND COIL WIRES.
5. ALL PIPE AND FITTINGS SHALL BE PVC SCHEDULE 80 UNLESS OTHERWISE SPECIFIED.
6. THE CONTRACTOR SHALL SUBMIT TO THE ENGINEER FOR APPROVAL, PRIOR TO PURCHASE, THE TYPE OF WATERPROOF CONNECTION THAT WILL BE USED.
7. VALVE BOX SHALL BE ONE OF THE FOLLOWING CASES AS SPECIFIED ON PLANS:
 CASE 1 - CONCRETE BOX WITH CONCRETE COVER.
 CASE 2 - CONCRETE BOX WITH LOCKING CAST IRON COVER.
 CASE 3 - PLASTIC BOX WITH LOCKING PLASTIC COVER.
8. CRUSHED ROCK SHALL COVER VALVE BOX PIPE OPENINGS TO PREVENT SOIL ENTRY.

SYMBOL ON PLAN



AMERICAN PUBLIC WORKS ASSOCIATION - SOUTHERN CALIFORNIA CHAPTER		
PROMULGATED BY THE PUBLIC WORKS STANDARDS INC., GREENBOOK COMMITTEE 1984	REMOTE CONTROL VALVE	STANDARD PLAN METRIC 506 - 1 SHEET 1 OF 1
USE WITH STANDARD SPECIFICATIONS FOR PUBLIC WORKS CONSTRUCTION		

SEE RDMD STANDARD PLAN 506-1-OC FOR CONDITIONS

The following Standard Plans for Public Works Construction, 1997 Edition, of the American Public Works Association (Southern California Chapter) and Associated General Contractors of California (Southern California Districts) have been adopted by the Orange County Resources & Development Management Department (RDMD) with conditions which shall apply to RDMD use. The conditions are listed below.

<u>APWA #</u>	<u>RDMD #</u>	<u>Name and Conditions</u>
506-1	506-1-0C	<u>Remote Control Valve</u>

1. Use Class 315 P.V.C. pipe and Schedule 40 P.V.C. fittings for sizes 2" (50mm) or greater.
Use Schedule 40 P.V.C. pipe and fittings for sizes 1/2" (38mm) or less.
2. Provide one controller valve I.D. tags per valve. I.D. tags shall be polyurethane 2 1/4" x 2 3/4" (57mm x 69mm) minimum with 1/8" (28mm) block letters on a contrasting background.
3. All Remote Control Valves and Enclosures shall be located outside of designated playing field (i.e., baseball, soccer, etc.).
4. Distance between bottom of valve box cover and top of valve shall be 4" (100mm).

ORANGE COUNTY RESOURCES & DEVELOPMENT MANAGEMENT DEPARTMENT

Approved



H. I. Nakasone, Chief Engineer

Adopted: Res. 86-1141 Revised: Res. 88-1341; 91-1481; 06-010

STD. PLAN

506-1-0C

APWA STANDARD PLAN - REMOTE CONTROL VALVE

SHT. 1 OF 1

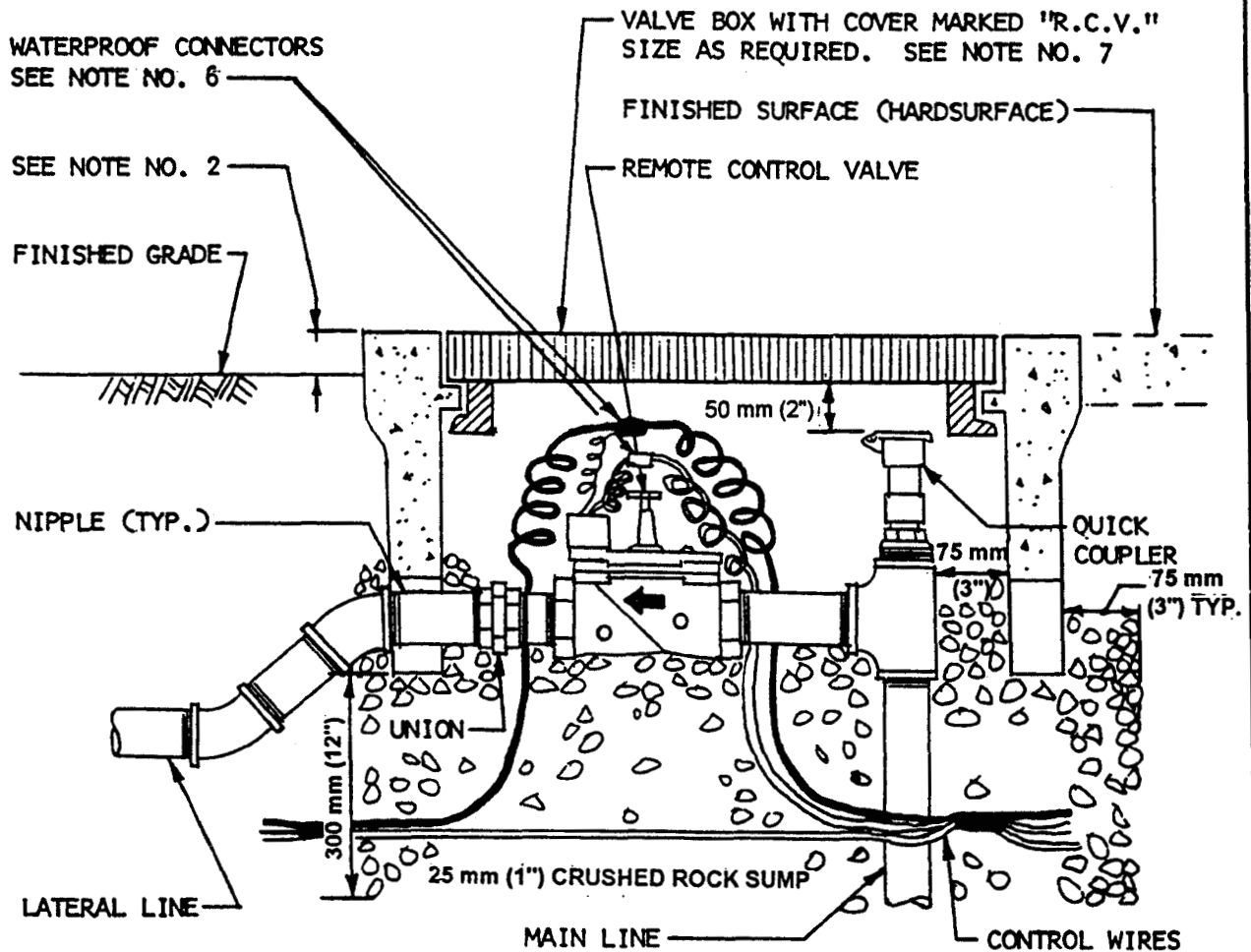

NOTES:

1. AREA AROUND BOX CAN EITHER BE PLANTED, HARDSURFACE OR A COMBINATION.
2. TOP OF BOX:
 - 12 mm (1/2") ABOVE GRADE FOR LAWN
 - 25 mm (1") ABOVE GRADE FOR GROUND COVER OR SHRUBS
3. CLOSE NIPPLES SHALL NOT BE USED.
4. PROVIDE TWO FOOT EXPANSION LOOP AT EACH WIRE CONNECTION IN VALVE BOX AND COIL WIRES.
5. ALL PIPE AND FITTINGS SHALL BE PVC SCHEDULE 80 UNLESS OTHERWISE SPECIFIED.
6. THE CONTRACTOR SHALL SUBMIT TO THE ENGINEER FOR APPROVAL, PRIOR TO PURCHASE, THE TYPE OF WATERPROOF CONNECTION THAT WILL BE USED.
7. VALVE BOX SHALL BE ONE OF THE FOLLOWING CASES AS SPECIFIED ON PLANS:
 - CASE 1 - CONCRETE BOX WITH CONCRETE COVER.
 - CASE 2 - CONCRETE BOX WITH LOCKING CAST IRON COVER.
 - CASE 3 - PLASTIC BOX WITH LOCKING PLASTIC COVER.
8. CRUSHED ROCK SHALL COVER VALVE BOX PIPE OPENINGS TO PREVENT SOIL ENTRY.

SYMBOL ON PLAN



AMERICAN PUBLIC WORKS ASSOCIATION - SOUTHERN CALIFORNIA CHAPTER		
<small>PROMULGATED BY THE PUBLIC WORKS STANDARDS INC., GREENBOOK COMMITTEE 1984</small>	REMOTE CONTROL VALVE WITH QUICK COUPLER	<small>STANDARD PLAN METRIC</small> 507 - 1 <small>SHEET 1 OF 1</small>
<small>USE WITH STANDARD SPECIFICATIONS FOR PUBLIC WORKS CONSTRUCTION</small>		

SEE RDMD STANDARD PLAN 507-1-OC FOR CONDITIONS

The following Standard Plans for Public Works Construction, 1997 Edition, of the American Public Works Association (Southern California Chapter) and Associated General Contractors of California (Southern California Districts) have been adopted by the Orange County Resources & Development Management Department (RDMD) with the conditions which shall apply to RDMD use. The conditions are listed below.

<u>APWA #</u>	<u>RDMD #</u>	<u>Name and Conditions</u>
507-1	507-1-0C	<u>Remote Control Valve with Quick Coupler</u>

1. Use Class 315 P.V.C. pipe and Schedule 40 P.V.C. fittings for size 2" (50mm) or greater. Use Schedule 40 P.V.C. pipe and fittings for sizes 1/2" (38mm) or less.
2. Provide one controller valve identification tag per valve. I.D. tags shall be polyurethane 2 1/4" x 2 3/4" (57mm x 69) with 1/8" (28mm) black letters on a contrasting background.
3. All remote control valves with quick coupler and enclosures shall be located outside of designated playing field (i.e., baseball diamond, soccer field, etc.).
4. Distance between bottom of valve box cover and top of valve shall be 4" (100mm).

ORANGE COUNTY RESOURCES & DEVELOPMENT MANAGEMENT DEPARTMENT

Approved

H. I. Nakasone
H. I. Nakasone, Chief Engineer

Adopted: Res. 86-1141 Revised: Res. 88-1341; 91-1481; 06-010

STD. PLAN

507-1-0C

APWA STANDARD PLAN-REMOTE CONTROL VALVE W/QUICK COUPLER

SHT. 1 OF 1

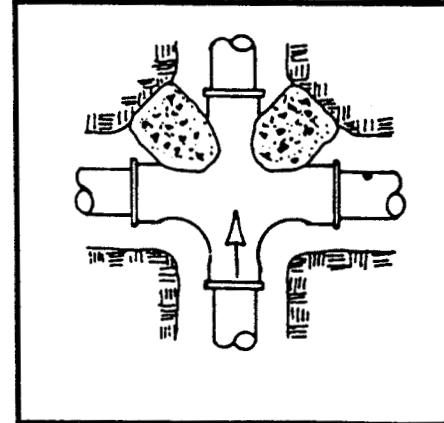
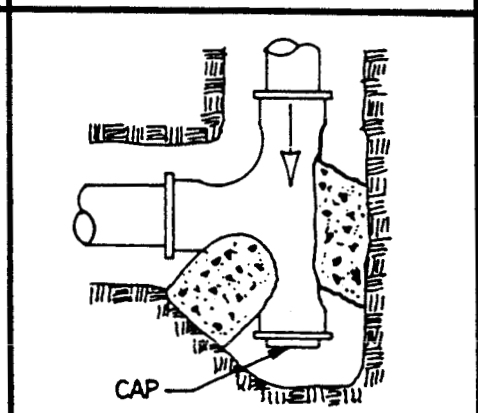
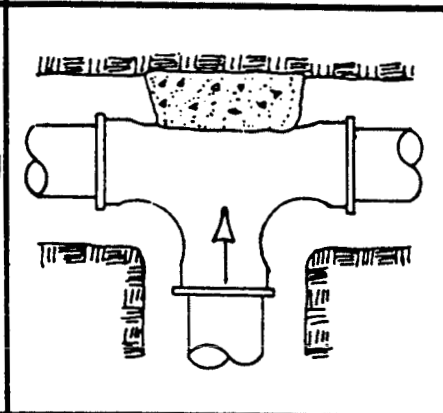
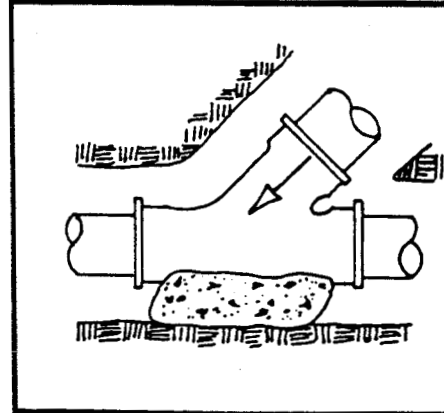
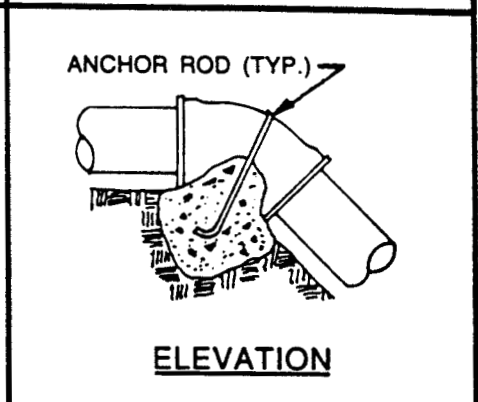
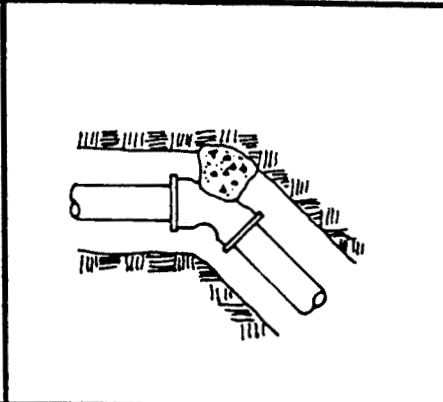
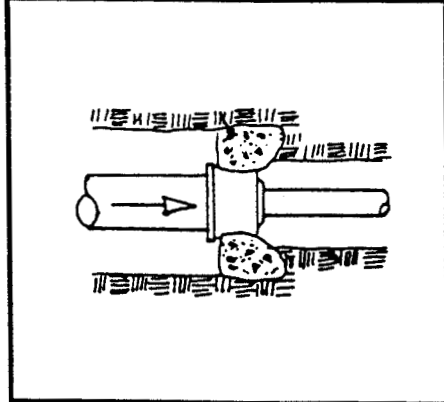
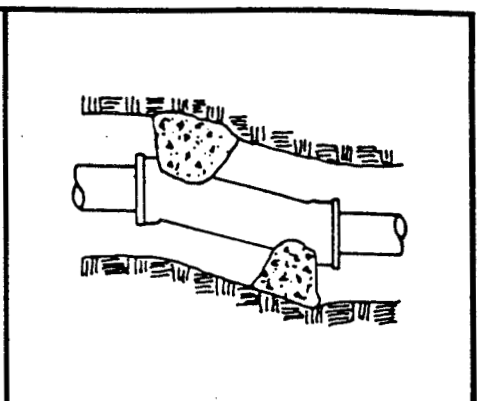
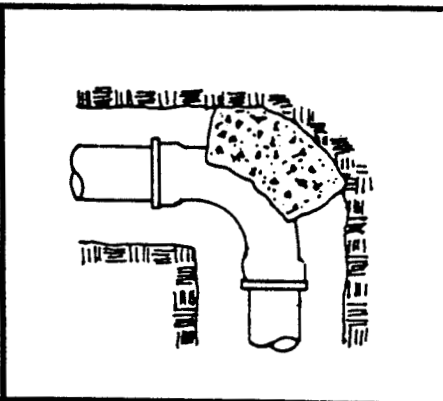
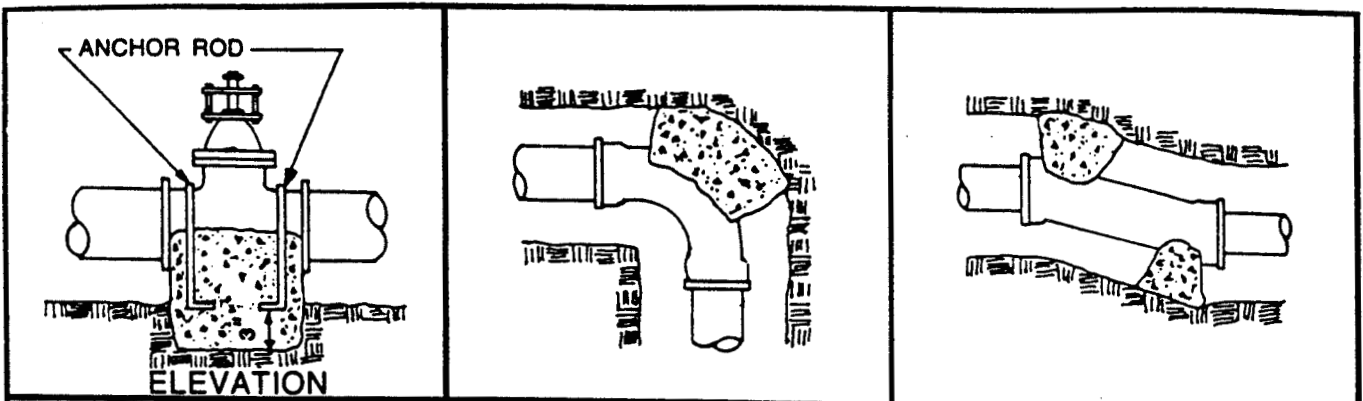

- NOTES:**
1. ALL PLASTIC PIPE TO BE INSTALLED ACCORDING TO THESE DETAILS UNLESS OTHERWISE NOTED OR DETAILED.
 2. THE PORTLAND CEMENT CONCRETE USED FOR THRUST BLOCKS SHALL BE 265-C-14 (450-C-2000) CONCRETE.
 3. ALL ANCHOR RODS SHALL BE GALVANIZED STEEL, MINIMUM 12 mm (1/2") DIAMETER, WRAPPED AROUND PIPE.
 4. SIZE OF THRUST BLOCKS SHALL BE SPECIFIED ON PLANS.
 5. THRUST BLOCKS SHALL BE USED FOR PLASTIC PIPES WITH 76 mm (3") DIAMETER OR LARGER.
 6. FLOW DIRECTION INDICATED BY →
 7. ALL VIEWS ARE PLAN VIEW UNLESS OTHERWISE SHOWN.

AMERICAN PUBLIC WORKS ASSOCIATION - SOUTHERN CALIFORNIA CHAPTER		
PROMULGATED BY THE PUBLIC WORKS STANDARDS INC., GREENBOOK COMMITTEE 1984	THRUST BLOCKS FOR PLASTIC PIPE	STANDARD PLAN METRIC 508 - 1 SHEET 1 OF 1
USE WITH STANDARD SPECIFICATIONS FOR PUBLIC WORKS CONSTRUCTION		

SEE RDMD STANDARD PLAN 508-1-OC FOR CONDITIONS

